

Name: \_\_\_\_\_

## GCSE (1 – 9)

# Compound Interest and Depreciation

### Instructions

- Use **black** ink or ball-point pen.
- Answer all Questions.
- Answer the Questions in the spaces provided  
– *there may be more space than you need.*
- Diagrams are **NOT** accurately drawn, unless otherwise indicated.
- You must **show all your working out.**

### Information

- The marks for each Question are shown in brackets  
– *use this as a guide as to how much time to spend on each Question.*

### Advice

- Read each Question carefully before you start to answer it.
- Keep an eye on the time.
- Try to answer every Question.
- Check your answers if you have time at the end

1 Jesy invests £8000 for  $n$  years in a savings account.

To find the value,  $V$ , of her investment after  $n$  years she uses the formula:

$$V = 8000 \times (1.025)^n$$

(a) Write down the annual rate of interest Jesy earns.

..... 2.5% .....

(1)

(b) Find the **total amount of interest** Jesy earns in three years.

$$8000 \times 1.025^3 = \text{£} 8615.13$$

$$8615.13 - 8000$$

..... £ 615.13 .....

(2)

(Total for question 1 is 3 marks)

2 Perrie invests £25000 for 3 years in a savings account.  
She gets 2.7% per annum compound interest.

Calculate the **total amount of interest** Perrie will get after 3 years.

$$25000 \times 1.027^3 = 27080.17$$

$$27080.17 - 25000 = \text{£} 2080.17$$

..... £ 2080.17 .....

(Total for question 2 is 3 marks)

3 Jade bought a house for £250 000.

In the first year the house price increased by 3%

In the second year the house price increased by 2%

In the third year the house price depreciated by 5%

Work out the value of the house at the end of 3 years.

$$350\,000 \times 1.03 \times 1.02 \times 0.95$$

$$= \text{£ } 349\,324.50$$

£ 349 324.50

(Total for question 3 is 3 marks)

4 Leigh-Anne invests £2500 for 4 years in a savings account.  
She gets 3% per annum compound interest.

How much money does Leigh-Anne have at the end of 4 years.

$$2500 \times 1.03^4 = \text{£ } 2813.77$$

£ 2813.77

(Total for question 4 is 2 marks)

- 5 Annie invests £9500 for 5 years in a savings account.  
She gets 1.8% per annum compound interest.

How much money does Annie have at the end of 5 years.

$$9500 \times 1.018^5 = £10386.34$$

£.....10386.34.....

(Total for question 5 is 2 marks)

- 6 Greg bought a new car for £18000.  
In the first year the value of the car depreciates by 30%.  
In the second year and the third year the car depreciates by 14%

Work out the value of the car after three years.

$$18000 \times 0.7 \times 0.86^2 = £9318.96$$

£.....9318.96.....

(Total for question 6 is 3 marks)

- 7 Nick bought a new car.  
Each year the car depreciates in value by 12%.

Work out the number of years it takes for the car to half in value.

$$0.88^2 = 0.7744$$

$$0.88^3 = 0.681472$$

$$0.88^4 = 0.59969536$$

$$0.88^5 = 0.5277319168$$

$$0.88^6 = 0.464404868 \quad [\text{less than } 0.5]$$

.....6.....years

(Total for question 7 is 3 marks)

- 8 Fearnie invests £5600 in a savings account.  
She gets 2% per annum compound interest.

After  $n$  years, Fearnie has £6061.62 in her account.  
Work out the value of  $n$ .

$$5600 \times 1.02^3 = \frac{5942.76}{\cancel{6119.27}}$$

$$5600 \times 1.02^4 = 6061.62 \quad \checkmark$$

.....4.....  
(Total for question 8 is 2 marks)

9 Alice is going to invest some money for 5 years.

She can choose from ~~of~~ two options:

Investment A: 2.7% compound interest per annum

Investment B: 2.8% simple interest per annum

Which investment should Alice choose

You must show your working.

A

$$100 \times 1.027^5 = 114.2$$

Increase of 14.2%

B

$$2.8 \times 5 = 14$$

Increase of 14%

She should choose Investment A

---

(Total for question 9 is 4 marks)

- 10 Matt wants to invest £8000 for three years. He can choose between Bank A and Bank B.

**Bank A**

1.2% compound interest  
per annum

**Bank B**

2% compound interest in  
the first year  
1% compound interest  
for each extra year

Which bank will give Matt the most interest after three years.  
You must show your working.

A

$$\begin{aligned} & \cancel{8000 \times 1.02^3} \\ & 8000 \times 1.012^3 \\ & = \pounds 8291.47 \end{aligned}$$

B

$$\begin{aligned} & 8000 \times 1.02 \times 1.01^2 \\ & = \pounds 8324.02 \end{aligned}$$

Bank B

(Total for question 10 is 4 marks)

11 Melvin invests £5000 in an account paying 2.5% compound interest per annum.

Charlie invests £4500 in an account paying 3% compound interest per annum.

Work out the difference between the amount of money Melvin has after 5 years and the amount of money Charlie has after 5 years.

$$\text{Melvin: } 5000 \times 1.025^5 = 5657.04$$

$$\text{Charlie: } 4500 \times 1.03^5 = 5216.73$$

$$5657.04 - 5216.73$$

$$= 440.31$$

£.....440.31.....

(Total for question 11 is 4 marks)

Name: \_\_\_\_\_

## GCSE (1 – 9)

# Scatter Graphs

### Instructions

- Use **black** ink or ball-point pen.
- Answer all Questions.
- Answer the Questions in the spaces provided  
– *there may be more space than you need.*
- Diagrams are **NOT** accurately drawn, unless otherwise indicated.
- You must **show all your working out.**

### Information

- The marks for each Question are shown in brackets  
– *use this as a guide as to how much time to spend on each Question.*

### Advice

- Read each Question carefully before you start to answer it.
- Keep an eye on the time.
- Try to answer every Question.
- Check your answers if you have time at the end

1 The scatter graph shows the scores of 15 students on their Biology and Physics tests.

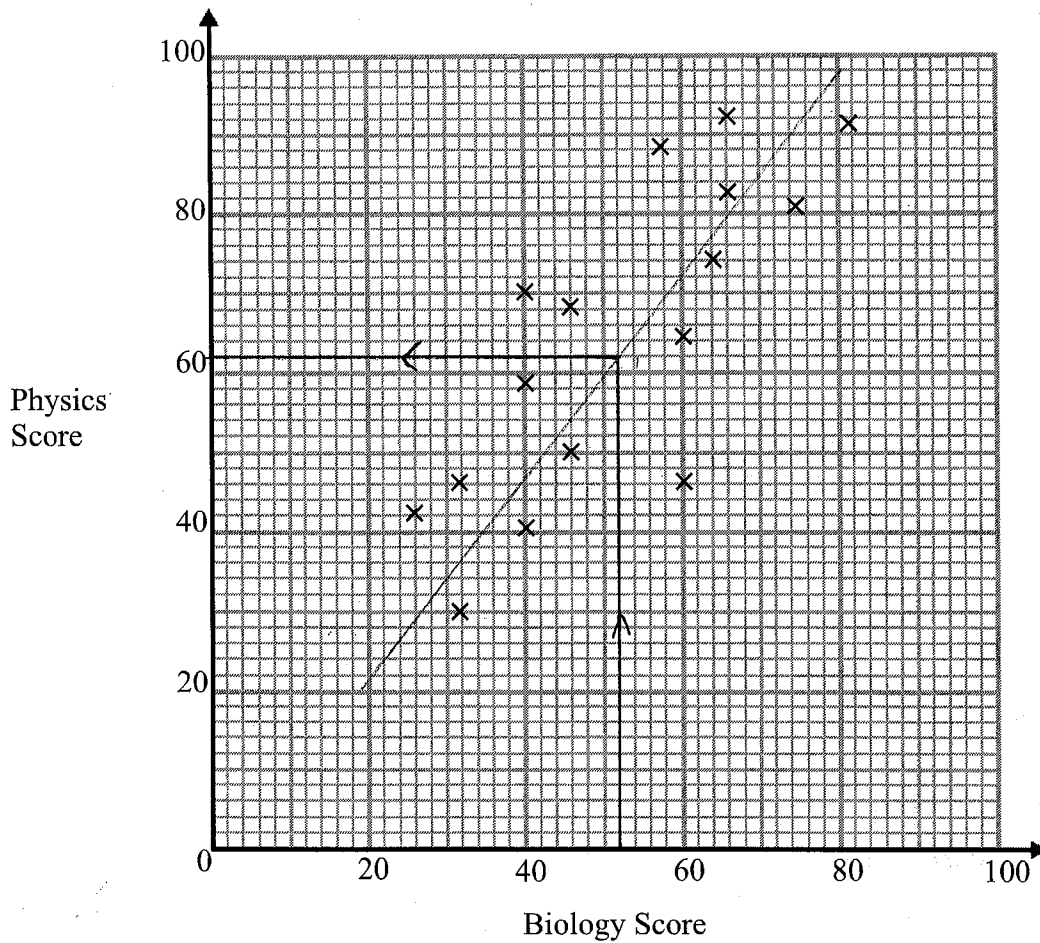

(a) What type of correlation does the scatter graph show?

..... positive .....  
(1)

(b) Another students scored 52 marks on their Biology test.  
Estimate the Physics score for this student.

..... 62 .....  
(2)

(Total for question 1 is 3 marks)

[58 - 66]

2

Gary recorded how many goals 10 football teams scored. He also recorded how many goals they conceded

The information is shown on the scatter graph.

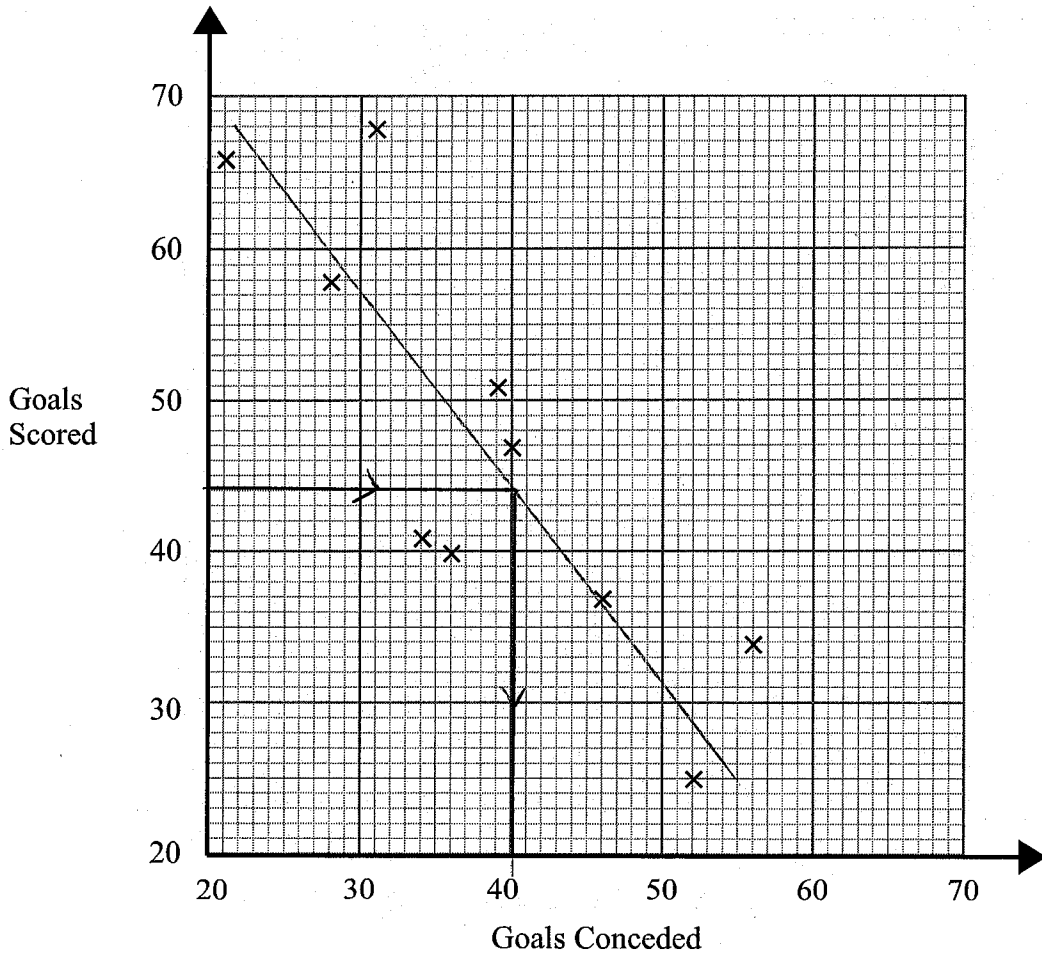

(a) What type of correlation does the scatter graph show?

negative (1)

(b) Another team have scored 44 goals.

Estimate the number of goals this team has conceded.

40 (2)

(Total for question 2 is 3 marks)

[39 - 42]

- 3 The average daytime temperature for 10 days is recorded.  
A shop also records its ice cream sales for each of the 10 days.

The scatter graph shows this information.

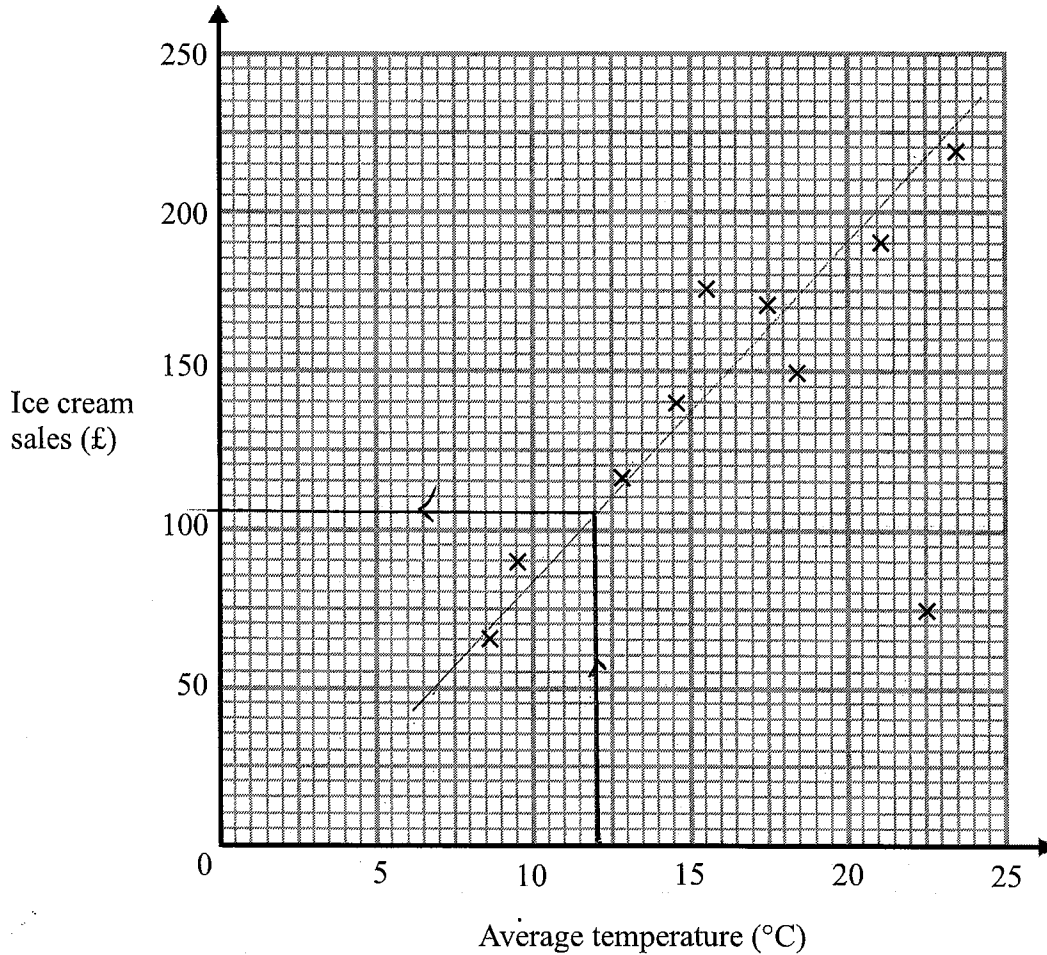

- (a) What type of correlation does the scatter graph show?

.....*positive*.....  
(1)

- (b) One of the points is an outlier. Write down the coordinates for this point.

(.....*22.5*.....), (.....*75*.....)  
(1)

- (c) On another day the temperature was 12°. Estimate the ice cream sales on this day.

£.....*105*.....  
*100 - 110* (2)

(Total for question 3 is 4 marks)

4 The scatter graph shows information about the test scores of some students in Maths and English.

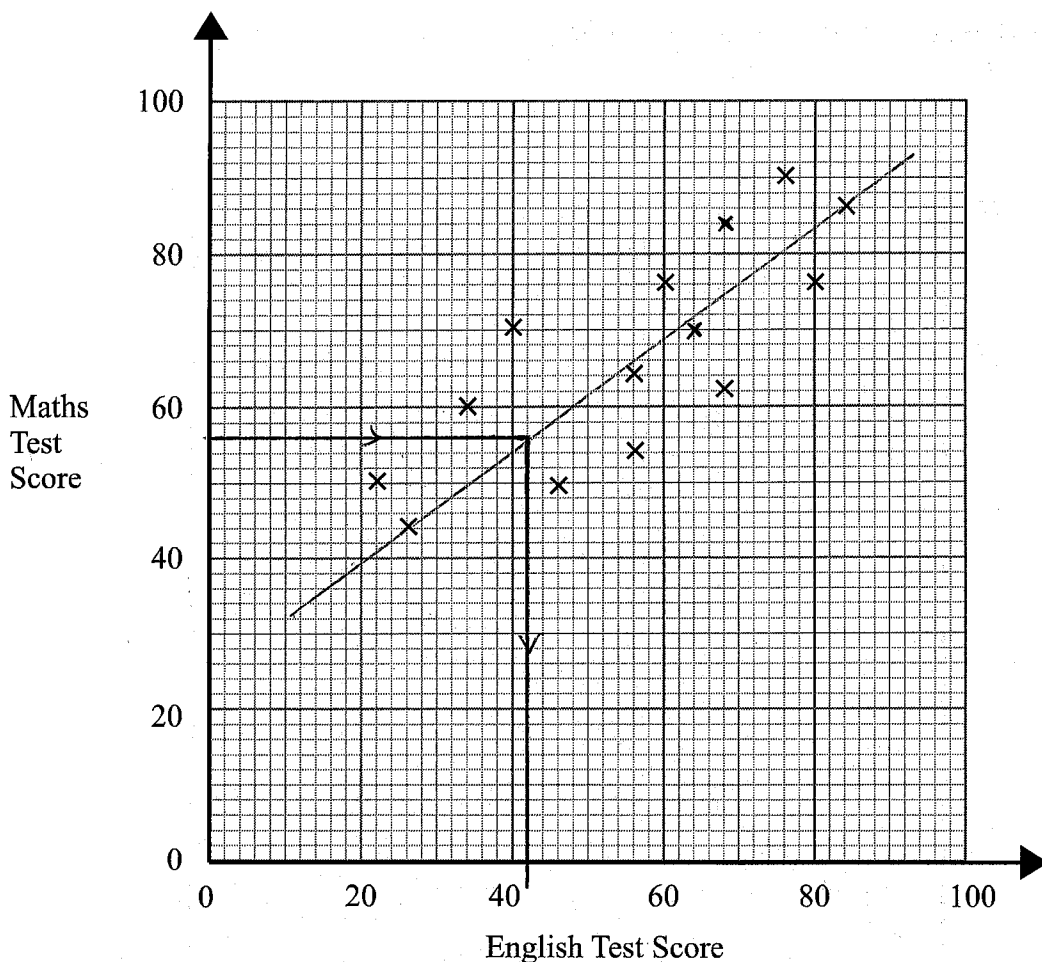

The table shows the test scores of two more students.

|                    |    |    |
|--------------------|----|----|
| Maths Test Score   | 70 | 84 |
| English Test Score | 64 | 68 |

(a) Show this information on the scatter graph. (1)

Another student scored 56 on the maths test.

(b) Use the scatter graph to estimate this student's score on the English test.

42  
 -----  
 [37 - 43] (2)  
 (Total for question 4 is 3 marks)

5 Wayne has data about the number of goals 10 football players had scored and the number of games they had played.

He was asked to display the data on a scatter graph.  
Here is his answer.

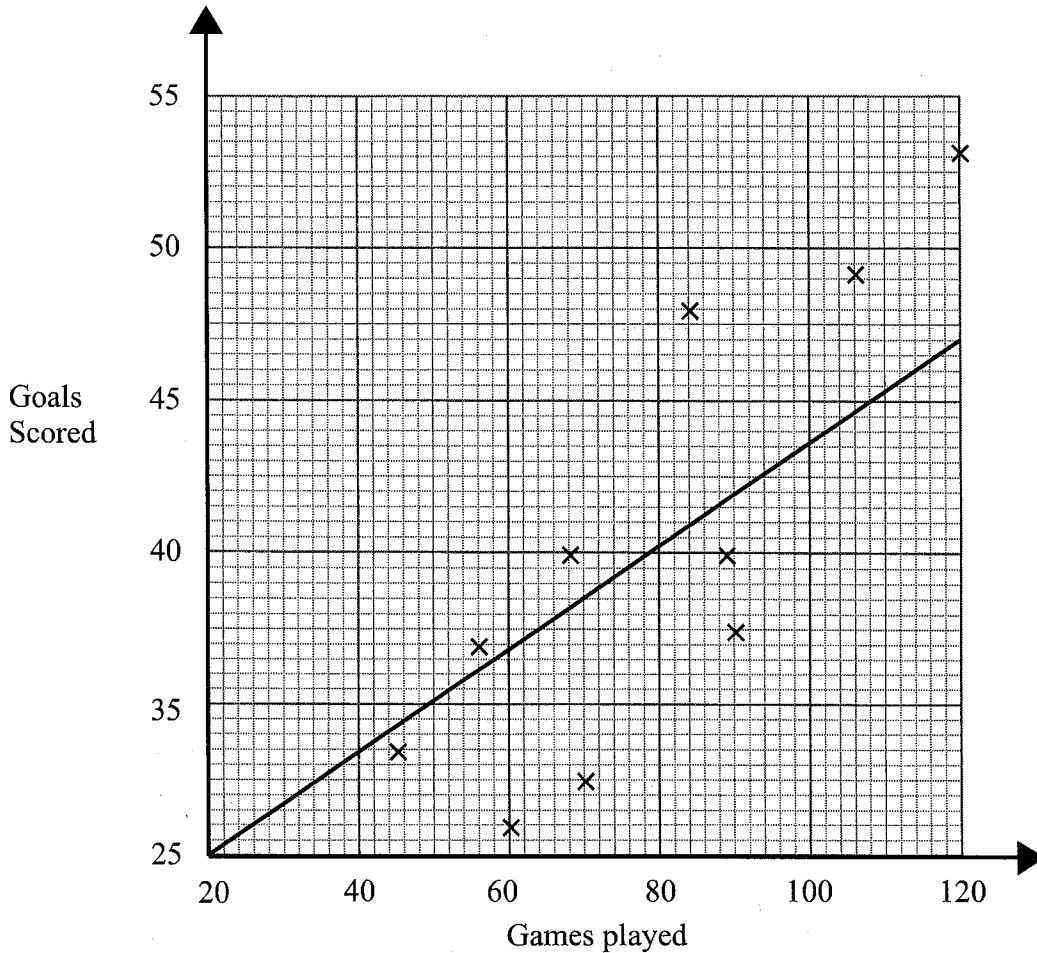

Wayne has plotted the points accurately.

Write down two things that are wrong with his answer.

- 1 Scale on y-axis is not linear
- 2 the line of best fit does not fit the correlation

(Total for question 5 is 2 marks)

- 6 The scatter graph shows information about the test scores of some students in Maths and the number of hours they spend watching TV a day.

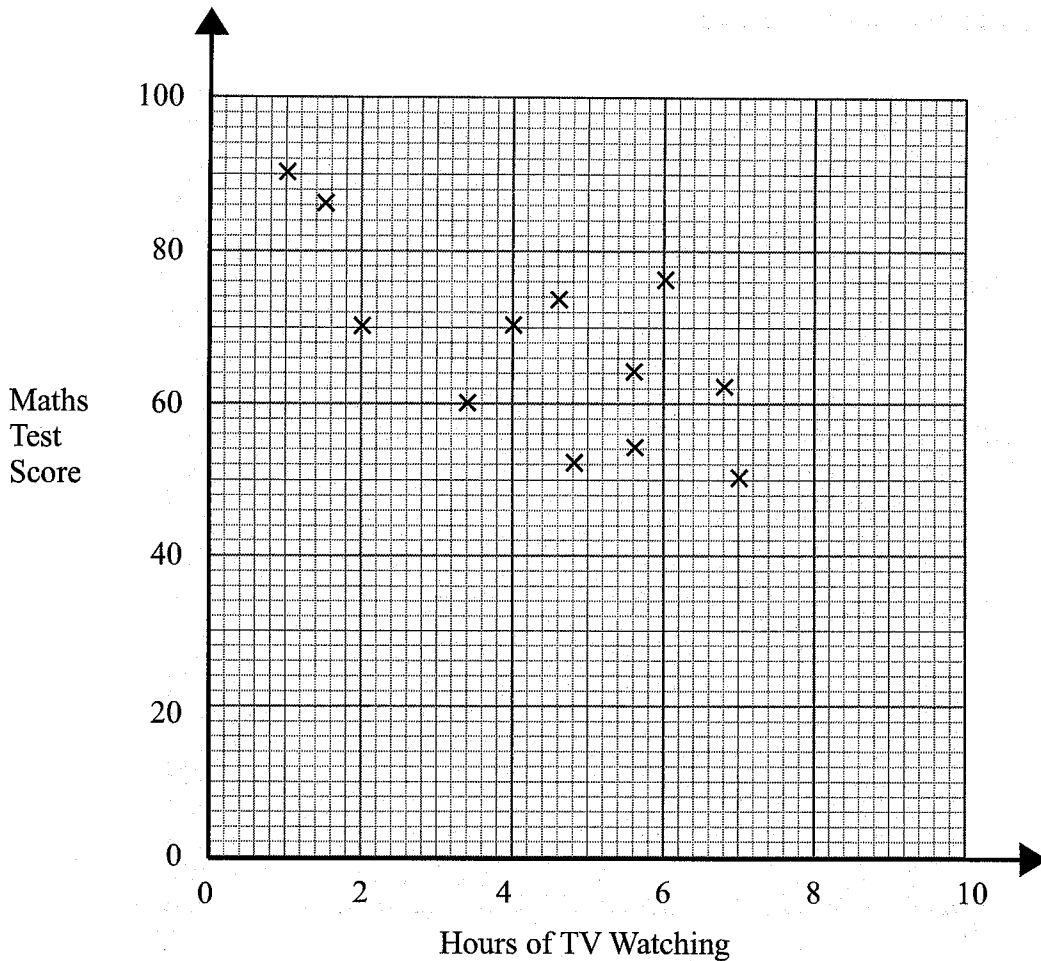

- (a) What type of correlation does the scatter graph show?

negative

(1)

Billy says,

"If I reduce the amount of TV I watch my Maths test score will improve."

- (b) Comment on what Billy says.

Just because Billy watches less TV it does  
not mean his score will improve. (He would probably need  
to revise more.)  
Correlation does not mean causation.

(1)

(Total for question 6 is 3 marks)

- 7 The average daytime temperature for 10 days is recorded.  
A shop also records its ice cream sales for each of the 10 days.

The scatter graph shows this information.

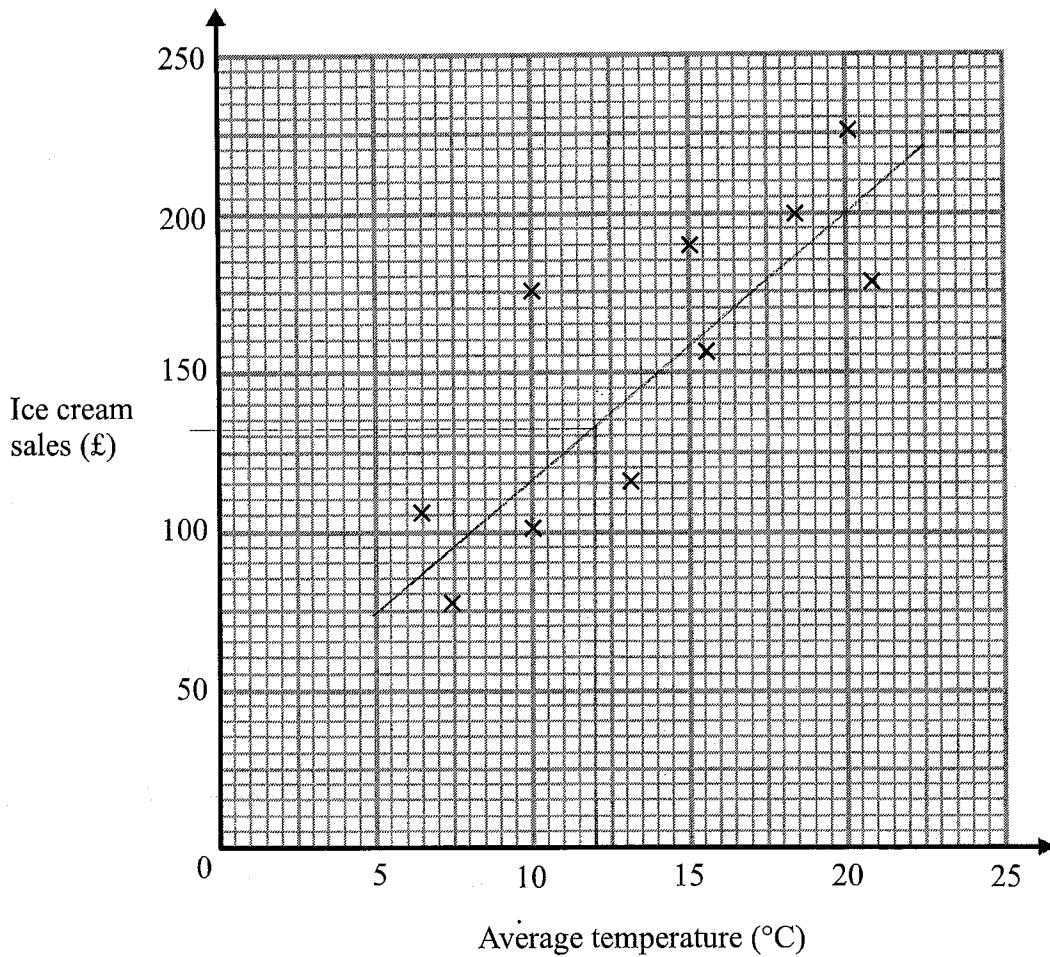

- (a) What type of correlation does the scatter graph show?

..... *positive* ..... (1)

- (b) On the 11<sup>th</sup> day the temperature was 12°. Estimate the ice cream sales on the 11th day.

..... *£132* .....  
..... *(125 - 145)* ..... (2)

- (c) The shop's manager wants to use the scatter graph to predict the ice cream sales for a day with an average temperature of 2°. Comment on the reliability of this prediction.

..... *It would not be a reliable prediction 2° is* .....  
..... *out of the range of data.* ..... (1)

**(Total for question 7 is 5 marks)**

Name: \_\_\_\_\_

## GCSE (1 – 9)

# Probability and Relative Frequency

### Instructions

- Use **black** ink or ball-point pen.
- Answer all questions.
- Answer the questions in the spaces provided – *there may be more space than you need.*
- Diagrams are **NOT** accurately drawn, unless otherwise indicated.
- You must **show all your working out.**

### Information

- The marks for each question are shown in brackets – *use this as a guide as to how much time to spend on each question.*

### Advice

- Read each question carefully before you start to answer it.
- Keep an eye on the time.
- Try to answer every question.
- Check your answers if you have time at the end

1 The probability that a biased dice will land on a 6 is 0.3

The dice is going to be rolled 200 times.

Work out an estimate for the number of times the dice will land on 6.

$$0.3 \times 200$$

60

(Total for question 1 is 2 marks)

2 The probability that a sunflower seed will germinate is 0.9

Alan is going to plant 50 sunflower seeds.

Work out an estimate for the number of seeds that will germinate.

$$0.9 \times 50$$

45

(Total for question 2 is 2 marks)

3 The probability that Frank scores a penalty is 0.86

Frank is going to take 50 penalties

Work out an estimate for the number of times Frank will score.

$$0.86 \times 50$$

43

(Total for question 3 is 2 marks)

4 The probability that Matt scores a penalty is 0.96

Matt is going to take 25 penalties.

Work out an estimate for the number of times Matt will score.

$$0.96 \times 25$$

24

(Total for question 4 is 2 marks)

5 In a bag there are only red counters, blue counters and white counters

A counter is taken at random from the bag.

The table shows the probability of the counter being red and blue.

|                    |     |      |       |
|--------------------|-----|------|-------|
| <b>Colour</b>      | Red | Blue | White |
| <b>Probability</b> | 0.5 | 0.3  | 0.2   |

Complete the table to show the probability that counter will be white.

$$0.5 + 0.3 = 0.8$$

$$1 - 0.8 = 0.2$$

(Total for question 5 is 2 marks)

6 In a box there are only black pens, blue pens and green pens

A pen is taken at random from the box.

The table shows the probability of the pen being black and blue.

|                    |       |      |       |
|--------------------|-------|------|-------|
| <b>Colour</b>      | Black | Blue | Green |
| <b>Probability</b> | 0.64  | 0.24 | 0.12  |

Complete the table to show the probability that pen will be green.

$$0.64 + 0.24 = 0.88$$

$$1 - 0.88 = 0.12$$

(Total for question 6 is 2 marks)

7 A biased spinner can land on red, blue, yellow and green.

The table shows the probabilities that the spinner will land on red, blue and yellow.

|                    |      |      |        |       |
|--------------------|------|------|--------|-------|
| <b>Colour</b>      | Red  | Blue | Yellow | Green |
| <b>Probability</b> | 0.25 | 0.34 | 0.22   | 0.19  |

Complete the table to show the probability that spinner will land on green.

$$0.25 + 0.34 + 0.22 = 0.81$$

$$1 - 0.81 = 0.19$$

(Total for question 7 is 2 marks)

8 In a bag there are only red counters, blue counters and white counters

number of red counters : number of blue counters : number of white counters = 5 : 4 : 3

A counter is taken at random from the bag.

| Colour      | Red            | Blue           | White          |
|-------------|----------------|----------------|----------------|
| Probability | $\frac{5}{12}$ | $\frac{4}{12}$ | $\frac{3}{12}$ |

Complete the table to show the probabilities of the counter being red, blue or white.

(Total for question 8 is 2 marks)

9 In a bag there are only black counters, white counters and red counters.

A counter is taken at random from the bag.

The table shows the probability of taking a black counter and a white counter.

| Colour      | Black          | White         | Red            |
|-------------|----------------|---------------|----------------|
| Probability | $\frac{3}{10}$ | $\frac{3}{5}$ | $\frac{1}{10}$ |

Complete the table to show the probabilities of the counter being red.

$$\frac{3}{10} + \frac{3}{5}$$

$$\frac{3}{10} + \frac{6}{10} = \frac{9}{10}$$

$$1 - \frac{9}{10} = \frac{1}{10}$$

(Total for question 9 is 2 marks)

10 A biased spinner can land on red, blue, yellow and green.

The table shows the probabilities that the spinner will land on red and yellow.

| Colour      | Red  | Blue | Yellow | Green |
|-------------|------|------|--------|-------|
| Probability | 0.18 | 0.28 | 0.26   | 0.28  |

The probability of landing on blue is the same as the probability of landing on green.

Complete the table to show the probabilities of spinner landing on blue and green.

$$0.18 + 0.26 = 0.44$$

$$1 - 0.44 = 0.56$$

$$\frac{0.56}{2} = 0.28$$

(Total for question 10 is 2 marks)

- 11 A biased spinner can land on red, blue, yellow and green.

The table shows the probabilities that the spinner will land on red, blue and yellow.

|             |     |      |        |       |
|-------------|-----|------|--------|-------|
| Colour      | Red | Blue | Yellow | Green |
| Probability | 0.3 | 0.25 | 0.15   |       |

- (a) Complete the table.

$$0.3 + 0.25 + 0.15 = 0.7$$

$$1 - 0.7 = 0.3$$

(2)

Kelly is going to spin the spinner 60 times.

- (b) Work out an estimate for the number of times the spinner will land on red.

$$60 \times 0.3 = 18$$

18

(2)

(Total for question 11 is 4 marks)

- 12 In a bag there are only red counters, blue counters and white counters.

A counter is taken at random from the bag.

The table shows the probability of getting a red counter.

|             |     |      |       |
|-------------|-----|------|-------|
| Colour      | Red | Blue | White |
| Probability | 0.2 | 0.4  | 0.4   |

The probability of getting a blue counter is the same as the probability of getting a white counter.

- (a) Complete the table.

$$1 - 0.2 = 0.8$$

$$\frac{0.8}{2} = 0.4$$

There are 18 red counters in the bag.

(2)

- (b) Work out the total number of counters in the bag.

$$\begin{array}{r} 0.2x = 18 \\ \times 5 \qquad \times 5 \end{array}$$

$$x = 90$$

90

(2)

(Total for question 13 is 4 marks)

- 13 A biased spinner can land on 1, 2, 3 or 4.  
The table shows the probabilities that the spinner will land on 2 and 4.

|             |      |      |      |      |
|-------------|------|------|------|------|
| Number      | 1    | 2    | 3    | 4    |
| Probability | 0.34 | 0.32 | 0.17 | 0.17 |

$$2x \qquad \qquad \qquad x$$

The probability that the spinner will land on 1 is **twice** the probability that the spinner will land on 3.

- (a) Complete the table.

$$0.32 + 0.17 = 0.49$$

$$1 - 0.49 = 0.51$$

$$3x = 0.51$$

(2)

$$x = 0.17$$

$$2x = 0.34$$

Johnny is going to spin the spinner 200 times.

- (b) Work out an estimate for the number of times the spinner will land on 2.

$$200 \times 0.32 = 64$$

$$\frac{64}{(2)}$$

(Total for question 13 is 4 marks)

- 14 The table shows the probabilities that a biased dice will land on 1, on 2, on 3, on 5 and on 6.

|             |      |     |      |      |      |      |
|-------------|------|-----|------|------|------|------|
| Number      | 1    | 2   | 3    | 4    | 5    | 6    |
| Probability | 0.14 | 0.2 | 0.08 | 0.24 | 0.13 | 0.21 |

The dice is rolled 200 times.

Work out an estimate for the number of times the dice will land on 2 or on 4.

$$0.14 + 0.2 + 0.08 + 0.13 + 0.21 = 0.76$$

$$1 - 0.76 = 0.24$$

$$2 \text{ or } 4 : 0.2 + 0.24 = 0.44$$

$$200 \times 0.44 = 88$$

$$\frac{88}{(2)}$$

(Total for question 14 is 3 marks)

15 In a box there are only red pens, blue pens, black pens and green pens.

A pen is taken at random from the box.

The table shows the probabilities that the pen will be red or will be green.

|                    |      |      |       |       |
|--------------------|------|------|-------|-------|
| <b>Colour</b>      | Red  | Blue | Black | Green |
| <b>Probability</b> | 0.42 | $x$  | $3x$  | 0.14  |

The probability that the pen will be black is three times the probability that the pen will be blue.

There are 28 green pens in the box.

Work out the number of black pens in the box.

$$0.42 + 0.14 = 0.56$$

$$1 - 0.56 = 0.44$$

$$4x = 0.44$$

$$x = 0.11$$

$$3x = 0.33$$

$$0.14 \times y = 28$$

$$y = 200$$

$$0.33 \times 200 = \underline{66}$$

66

(Total for question 15 is 4 marks)

16 In a bag there are only red counters, blue counters, green counters and yellow counters.

A counter is taken at random from the bag.

The table shows the probabilities that the counter will be green or will be yellow.

| Colour      | Red | Blue | Green | Yellow |
|-------------|-----|------|-------|--------|
| Probability |     |      | 0.35  | 0.20   |

The probability that the counter will be red is twice the probability that the counter will be blue.

There are 21 green counters in the bag.

Work out the number of red counters in the bag.

$$0.35 + 0.2 = 0.55$$

$$1 - 0.55 = 0.45$$

$$3x = 0.45$$

$$x = 0.15$$

$$2x = 0.3$$

$$0.35y = 21$$

$$y = 60$$

$$0.3 \times 60 = 18$$

18

(Total for question 16 is 4 marks)

Name: \_\_\_\_\_

## GCSE (1 – 9)

# Averages from Frequency Tables

### Instructions

- Use **black** ink or ball-point pen.
- Answer all Questions.
- Answer the Questions in the spaces provided  
– *there may be more space than you need.*
- Diagrams are **NOT** accurately drawn, unless otherwise indicated.
- You must **show all your working out.**

### Information

- The marks for each Question are shown in brackets  
– *use this as a guide as to how much time to spend on each Question.*

### Advice

- Read each Question carefully before you start to answer it.
- Keep an eye on the time.
- Try to answer every Question.
- Check your answers if you have time at the end

- 1 The table shows information about the number of points scored in a game.

| Points |   | Frequency |           |
|--------|---|-----------|-----------|
| 0      | X | 9         | 0         |
| 1      | X | 11        | 11        |
| 2      | X | 18        | 36        |
| 3      | X | 7         | 21        |
| 4      | X | 4         | 16        |
| 5      | X | 1         | 5         |
|        |   | 50        | <u>89</u> |

Work out the mean number of points per game.

$$\frac{89}{50} = \frac{178}{100} = 1.78$$

.....1.78

(Total for question 1 is 3 marks)

- 2 The table shows information about the number of goals scored in a game by a football team.

| Points    | Frequency |    |
|-----------|-----------|----|
| 0         | 10        | 0  |
| 1         | 12        | 12 |
| 2         | x         | 2x |
| 3         | 7         | 21 |
| 4 or more | 0         | 0  |

The team scored a total of 55 goals.  
Find the value of x.

$$12 + 2x + 21 = 55$$

$$2x + 33 = 55$$

$$2x = 22$$

$$x = 11$$

.....11

(Total for question 2 is 3 marks)

3 The table shows information about the number of goals a team scored in 38 games.

| Points    | Frequency |
|-----------|-----------|
| 0         | 7         |
| 1         | 14        |
| 2         | 11        |
| 3         | 6         |
| 4 or more | 0         |

(a) Find the median number of goals scored.

.....  
|  
.....  
(1)

(b) Write down the mode

.....  
|  
.....  
(1)

(c) Work out the total number of goals the team scored in all 38 games.

$$\begin{aligned}0 \times 7 &= 0 \\1 \times 14 &= 14 \\2 \times 11 &= 22 \\3 \times 6 &= 18\end{aligned}$$

$$14 + 22 + 18 = 54$$

.....  
54  
.....  
(2)

**(Total for question 3 is 4 marks)**

4 Adam is measuring the heights in cm of his tomato plants.

| Height (cm)        | m.p | Frequency |
|--------------------|-----|-----------|
| $140 < h \leq 150$ | 145 | 7         |
| $150 < h \leq 160$ | 155 | 10        |
| $160 < h \leq 170$ | 165 | 15        |
| $170 < h \leq 180$ | 175 | 19        |
| $180 < h \leq 200$ | 190 | 9         |

m.p x f

1015

1550

2475

3325

1710

60

10075

(a) Estimate the mean height.  
Give your answer correct to 1 decimal place.

$$\frac{10075}{60} = 167.9 \text{ (1dp)}$$

.....167.9.....cm  
(3)

(b) Explain why your answer to part (a) is an estimate.

.....we do not know the exact height of each.....  
.....plant as the data is grouped.....  
(we use the midpoint to estimate the heights of plants (1)  
in each group)

(Total for question 4 is 4 marks)

5 The table below gives information about the time taken for 20 people to run 5 km.

| Time (minutes)   | m.p  | Frequency | $m.p \times f$ |
|------------------|------|-----------|----------------|
| $15 < t \leq 20$ | 17.5 | 3         | 52.5           |
| $20 < t \leq 25$ | 22.5 | 6         | 135            |
| $25 < t \leq 30$ | 27.5 | 7         | 192.5          |
| $30 < t \leq 40$ | 35   | 4         | 140            |
|                  |      |           | 520            |

(a) Find the class interval that contains the median.

$25 < t \leq 30$  .....minutes  
(1)

(b) Work out an estimate for the mean time.

$$\frac{520}{20} = 26$$

.....26.....minutes  
(3)

(Total for question 5 is 4 marks)

6 Michael recorded the maximum temperature every day in September.

The table shows information about his results.

| Temperature ( $^{\circ}\text{C}$ ) | $mp$ |          | Frequency | $mp \times f$ |
|------------------------------------|------|----------|-----------|---------------|
| $14 < t \leq 18$                   | 16   | $\times$ | 4         | 64            |
| $18 < t \leq 20$                   | 19   | $\times$ | 10        | 190           |
| $20 < t \leq 22$                   | 21   | $\times$ | 8         | 168           |
| $22 < t \leq 24$                   | 23   | $\times$ | 5         | 115           |
| $24 < t \leq 28$                   | 26   | $\times$ | 3         | 78            |

Calculate an estimate for the mean maximum temperature.

615

$$\frac{615}{30} = 20.5$$

.....20.5..... $^{\circ}\text{C}$

(Total for question 6 is 3 marks)

7 The frequency table shows the time taken for 100 people to travel to an event.

| Time (minutes)   | $mp$ |          | Frequency |
|------------------|------|----------|-----------|
| $0 < t \leq 10$  | 5    | $\times$ | 14        |
| $10 < t \leq 20$ | 15   | $\times$ | 16        |
| $20 < t \leq 30$ | 25   | $\times$ | 23        |
| $30 < t \leq 40$ | 35   | $\times$ | 29        |
| $40 < t \leq 50$ | 45   | $\times$ | 12        |
| $50 < t \leq 60$ | 55   | $\times$ | 6         |

$mp \times f$

70

240

575

1015

540

330

2770

(a) Find the percentage of people that travelled for more than 30 minutes to the event

$$29 + 12 + 6 = 47$$

$$\frac{47}{100} = 47\%$$

..... 47 ..... %  
(1)

(b) Find the class interval that contains the median.

.....  $20 < t \leq 30$  ..... minutes  
(1)

(c) Find an estimate for the mean time taken for people to travel to the event.

$$\frac{2770}{100} = 27.7$$

..... 27.7 ..... minutes  
(3)

(Total for question 7 is 5 marks)

8 The bar chart shows how many hours of homework 30 students did last week.

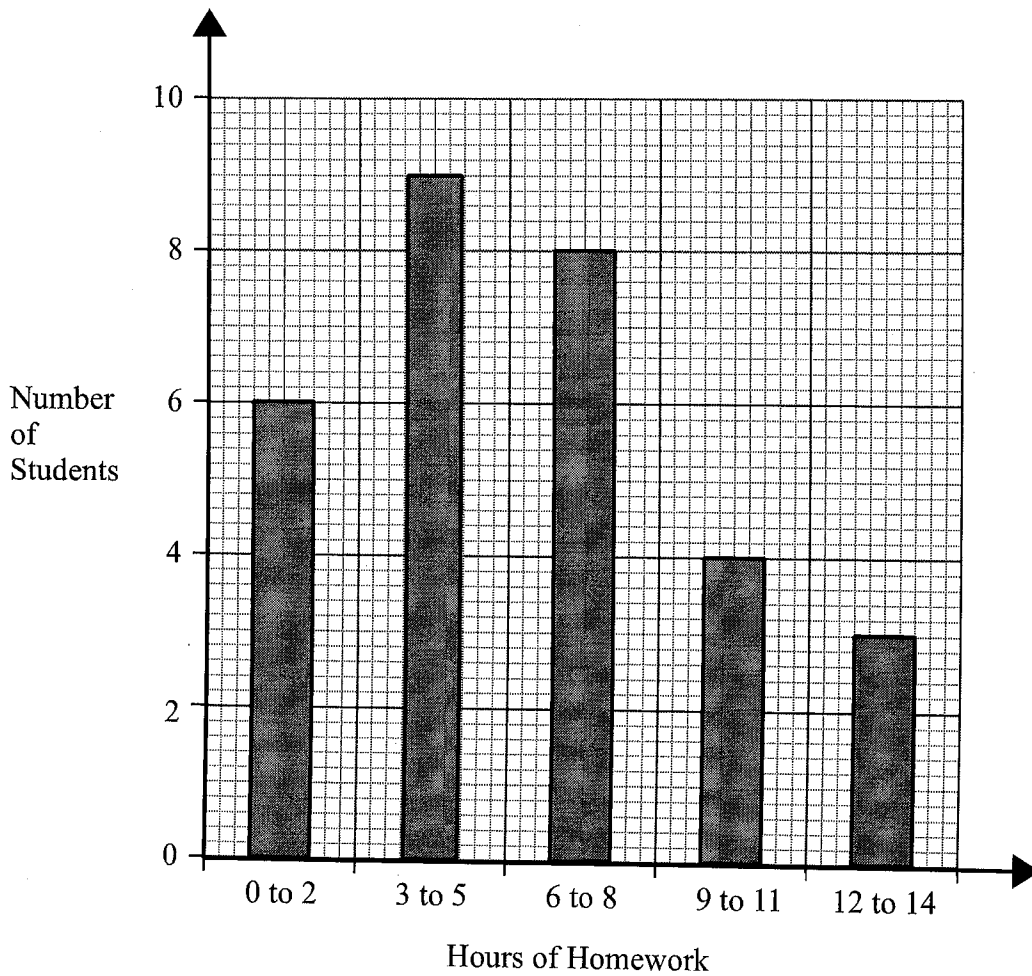

Calculate an estimate for the mean number of hours of homework.  
~~Give your answer to 2 decimal places.~~

$$\begin{aligned}
 1 \times 6 &= 6 \\
 4 \times 9 &= 36 \\
 7 \times 8 &= 56 \\
 10 \times 4 &= 40 \\
 13 \times 3 &= 39
 \end{aligned}$$

---

$$177$$

$$\frac{177}{30} = 5.9$$

..... 5.9 ..... hours

(Total for question 8 is 3 marks)

Name: \_\_\_\_\_

# GCSE (1 – 9)

## Plans and Elevations

### Instructions

- Use **black** ink or ball-point pen.
- Answer all questions.
- Answer the questions in the spaces provided  
– *there may be more space than you need.*
- Diagrams are **NOT** accurately drawn, unless otherwise indicated.
- You must **show all your working out.**

### Information

- The marks for each question are shown in brackets  
– *use this as a guide as to how much time to spend on each question.*

### Advice

- Read each question carefully before you start to answer it.
- Keep an eye on the time.
- Try to answer every question.
- Check your answers if you have time at the end

1 The diagram shows the plan, front elevation and side elevation of a solid shape, drawn on a centimetre grid.

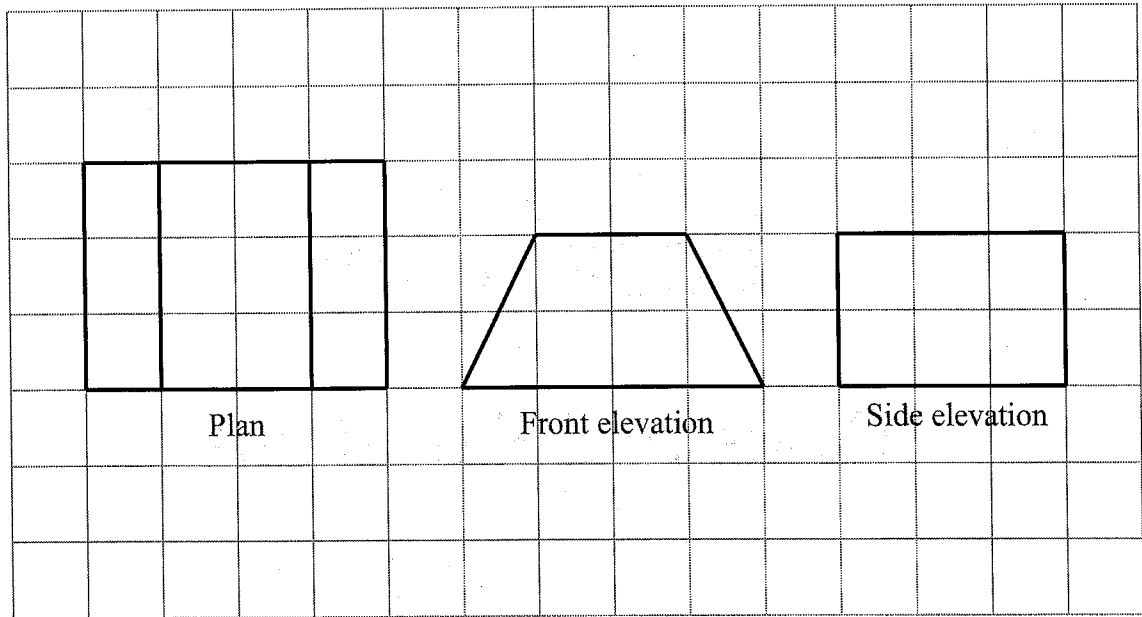

In the space below, draw a sketch of the solid shape.  
Give the dimensions of the solid on your sketch.

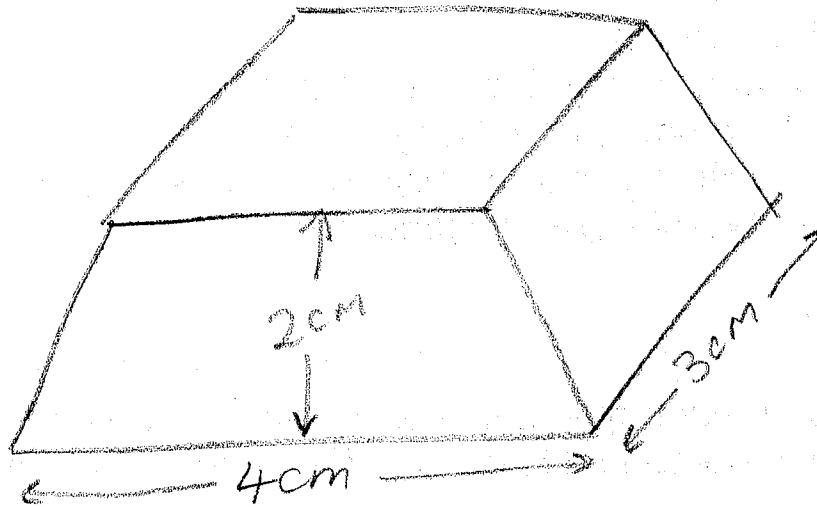

(Total for question 1 is 2 marks)

- 2 The diagram shows the plan, front elevation and side elevation of a solid shape, drawn on a centimetre grid.

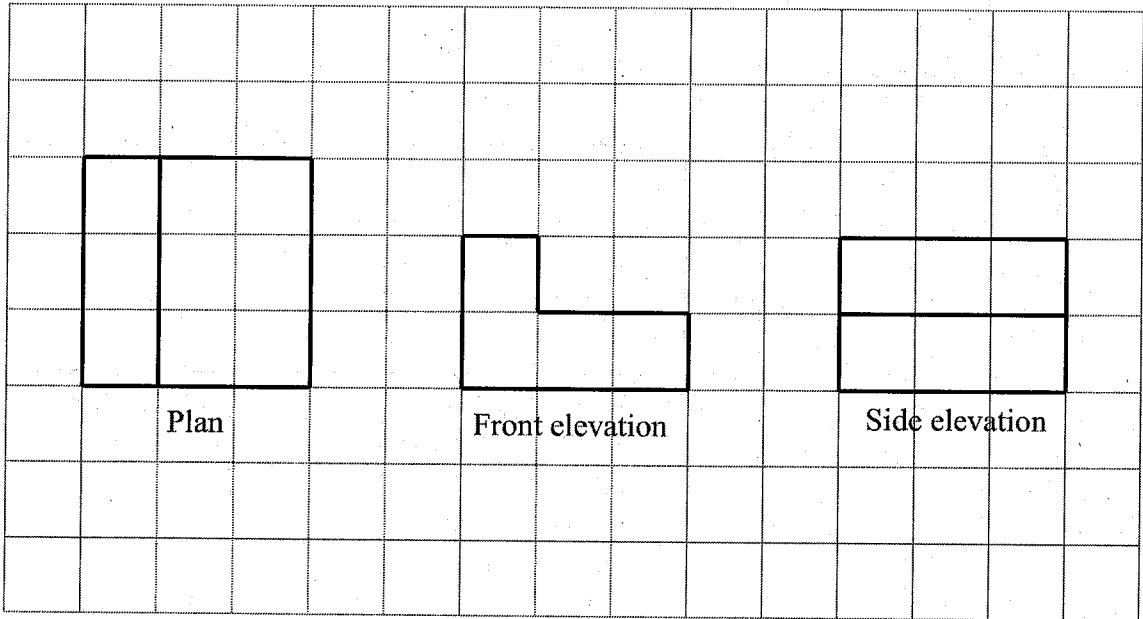

In the space below, draw a sketch of the solid shape.  
Give the dimensions of the solid on your sketch.

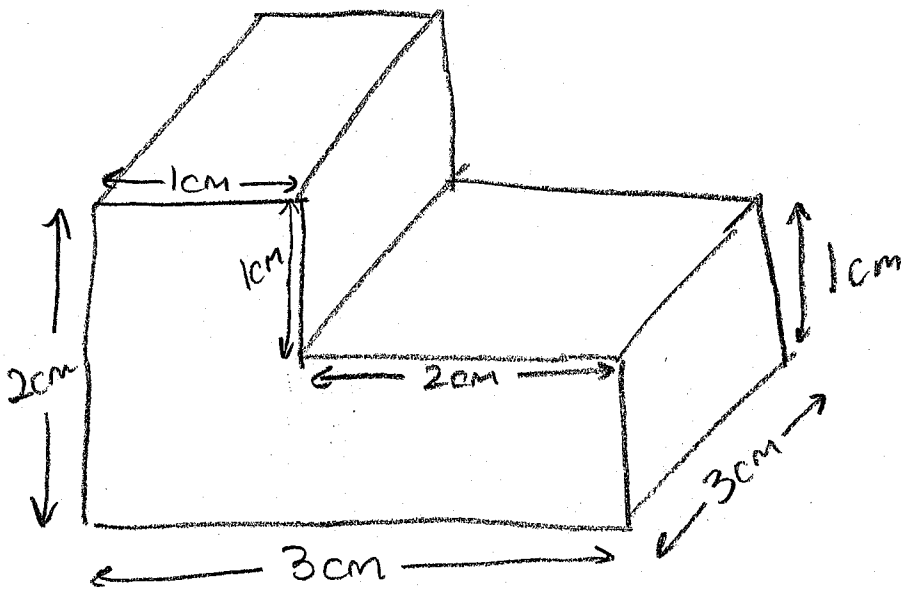

(Total for question 2 is 2 marks)

3

The diagram shows the plan, front elevation and side elevation of a solid shape, drawn on a centimetre grid.

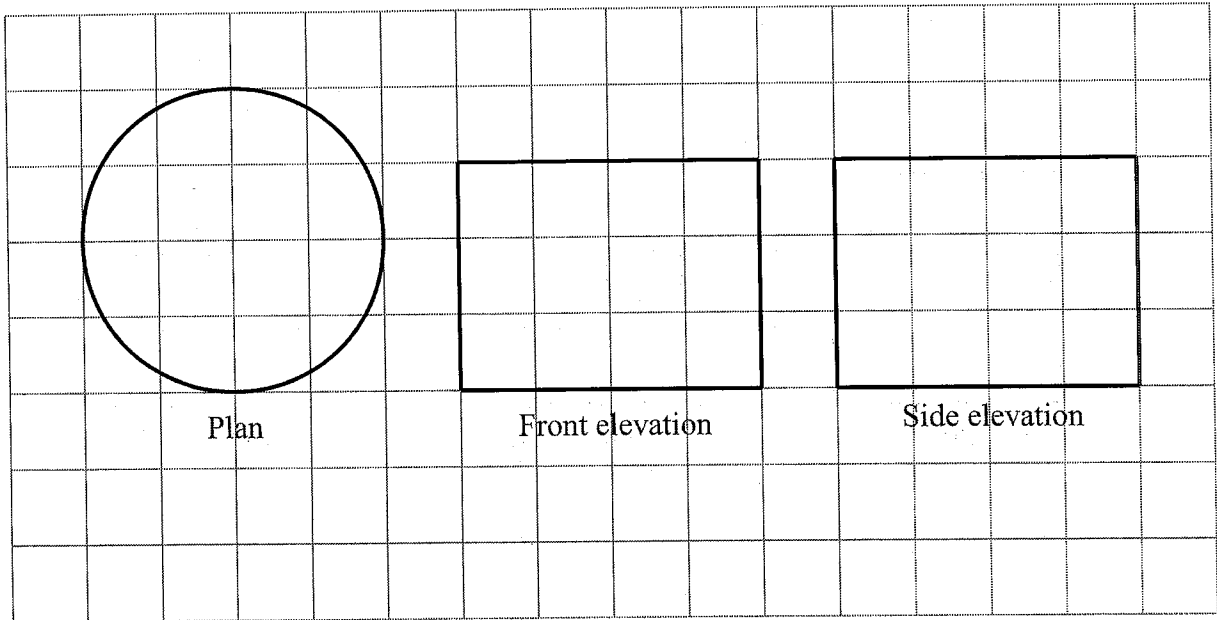

In the space below, draw a sketch of the solid shape.  
Give the dimensions of the solid on your sketch.

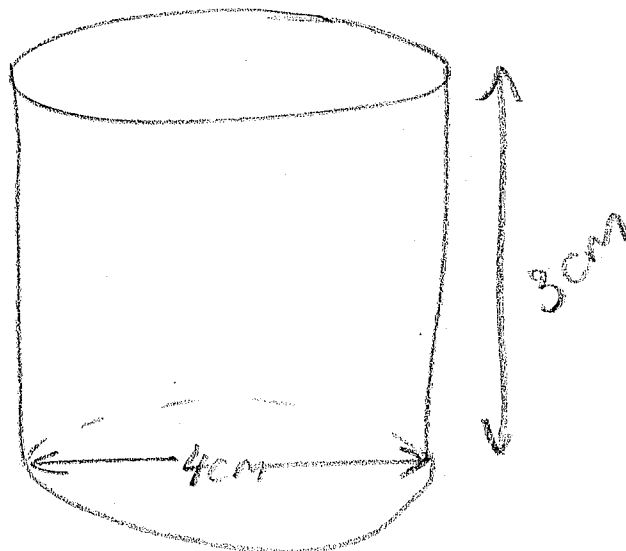

(Total for question 3 is 2 marks)

4 The diagram shows a solid made from centimetre cubes.

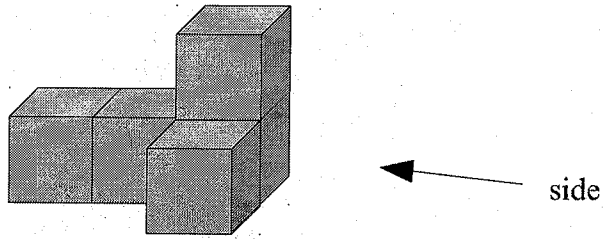

On the centimetre grid below draw the plan and the side elevation for the solid.

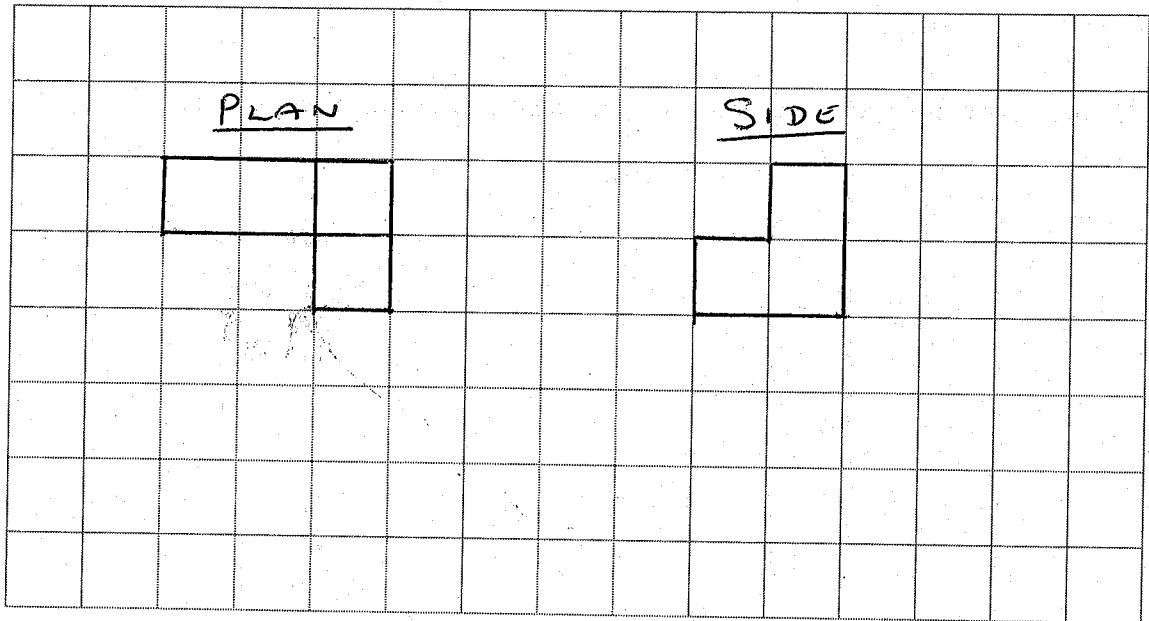

(Total for question 4 is 3 marks)

5

The diagram shows a cone with radius 3 cm and perpendicular height of 8 cm

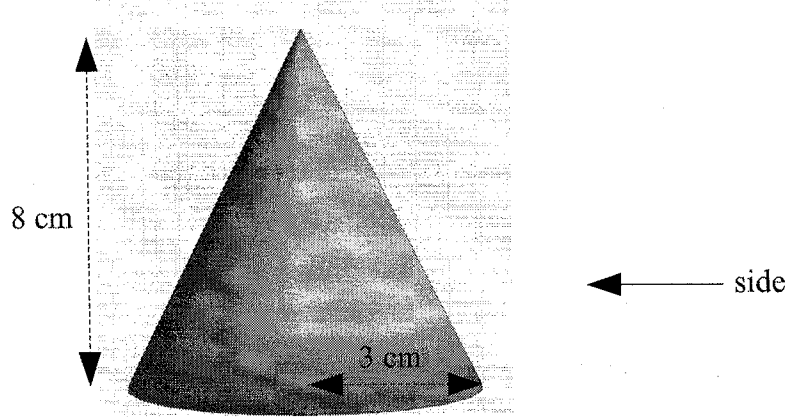

On the centimetre grid below, draw the plan and the side elevation of the cone.

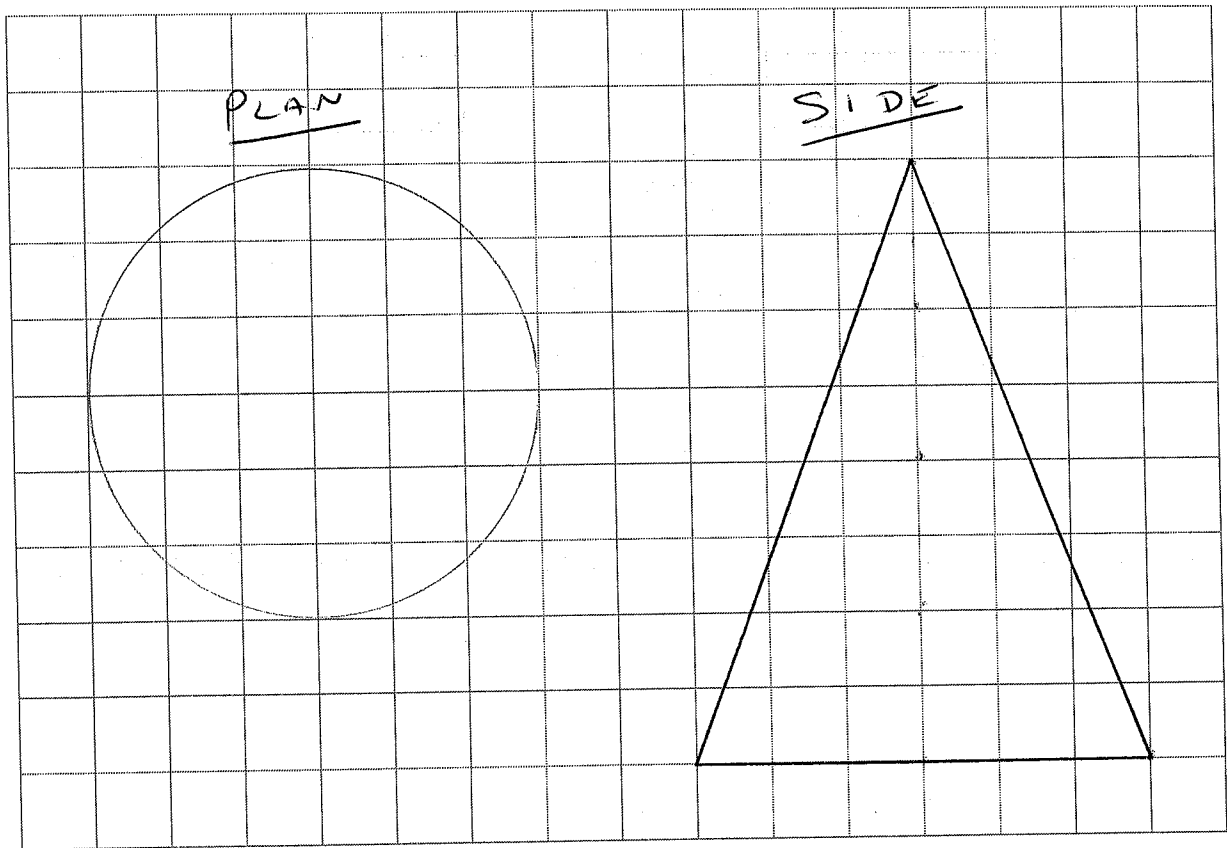

(Total for question 5 is 3 marks)

6 The diagram shows a prism.

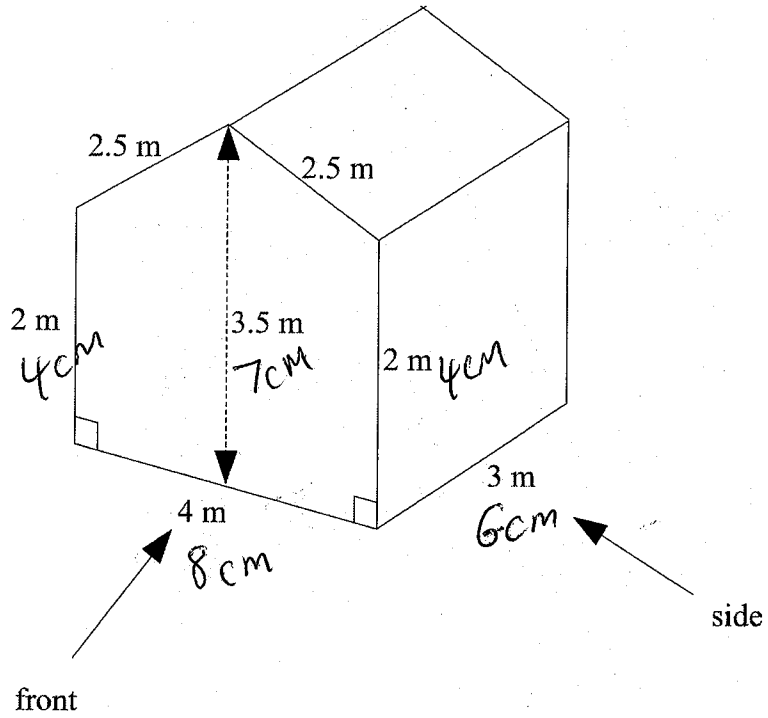

On the centimetre grid below, draw the front elevation and the side elevation of the prism.  
Use a scale of 2 cm to 1 m.

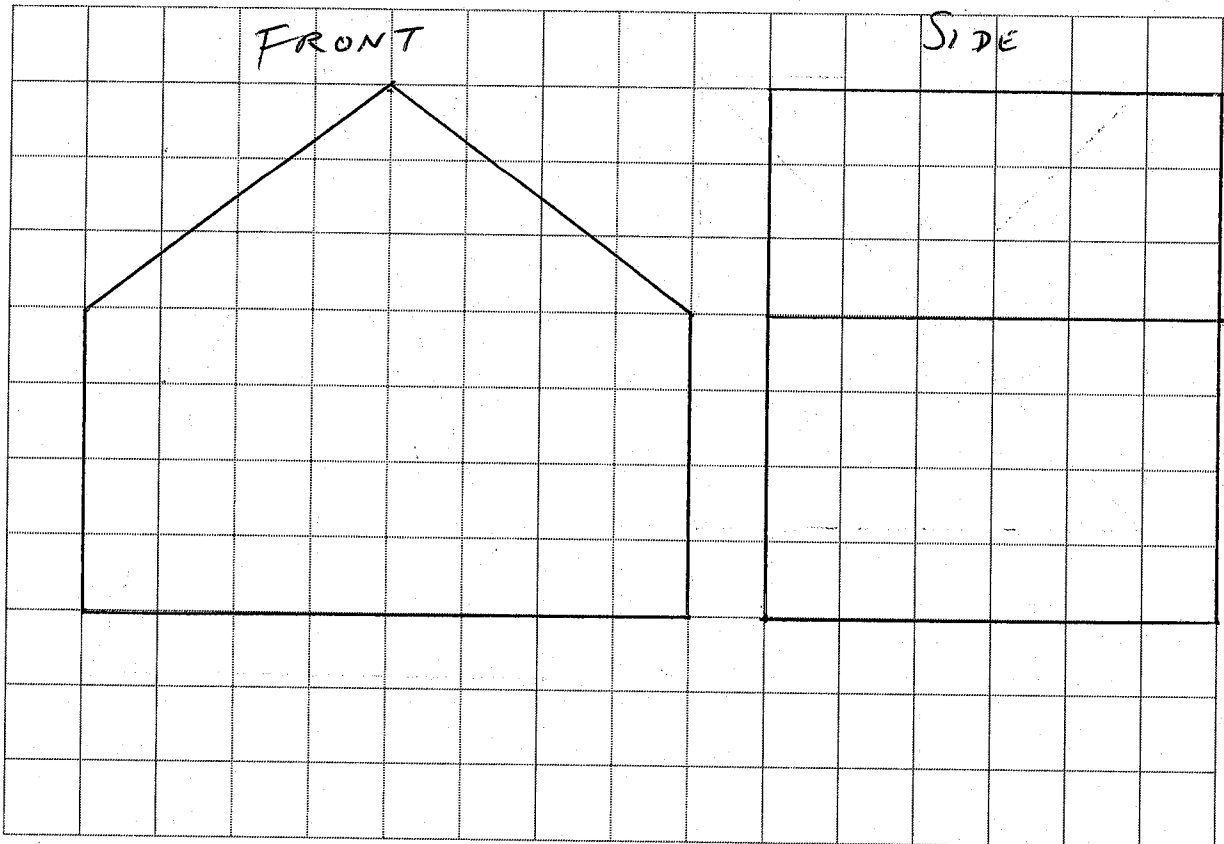

(Total for question 6 is 4 marks)

7

The diagram shows a square based pyramid with a perpendicular height of 400 cm.

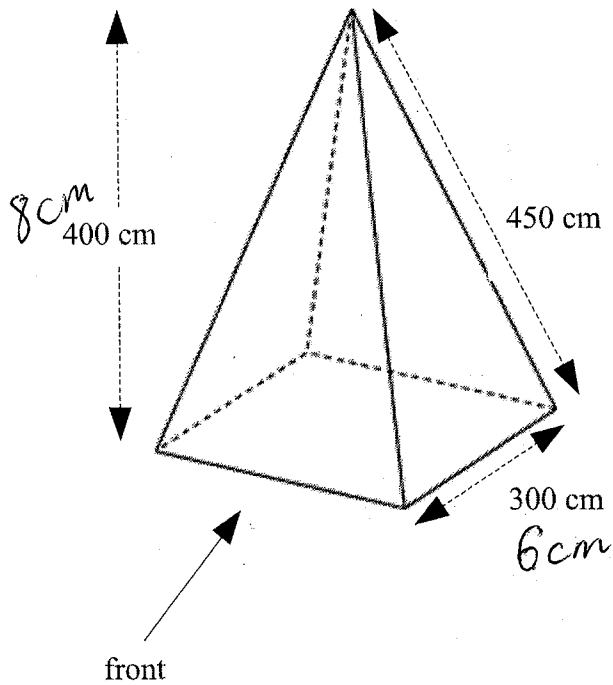

On the centimetre grid below, draw the plan and the front elevation of the pyramid.  
Use a scale of 2 cm to 1 m.

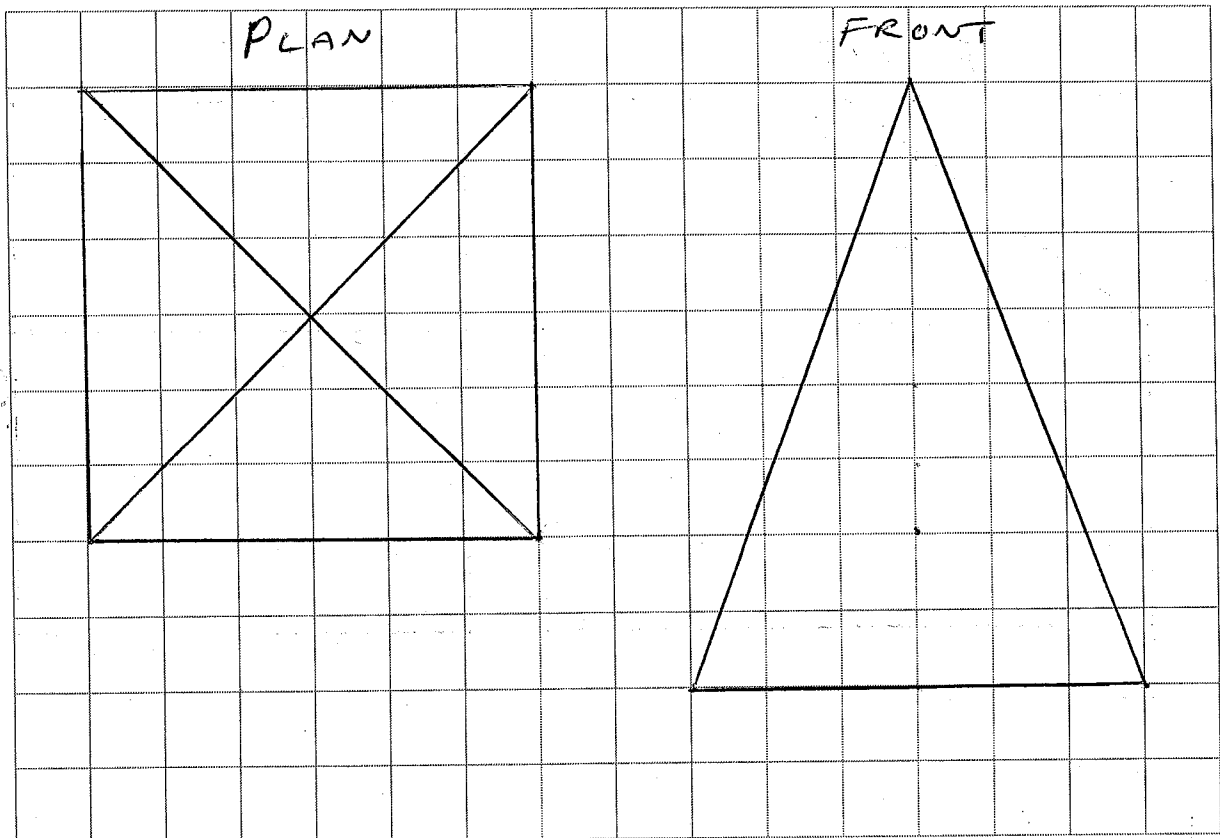

(Total for question 7 is 4 marks)

Name: \_\_\_\_\_

## GCSE (1 – 9)

### Bearings

#### Instructions

- Use **black** ink or ball-point pen.
- Answer all Questions.
- Answer the Questions in the spaces provided  
– *there may be more space than you need.*
- Diagrams are **NOT** accurately drawn, unless otherwise indicated.
- You must **show all your working out.**

#### Information

- The marks for each Question are shown in brackets  
– *use this as a guide as to how much time to spend on each Question.*

#### Advice

- Read each Question carefully before you start to answer it.
- Keep an eye on the time.
- Try to answer every Question.
- Check your answers if you have time at the end

1

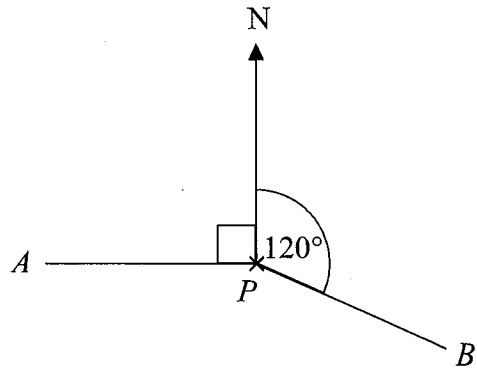

(a) Write down the bearing of  $B$  from  $P$ .

..... 120 °  
(1)

(b) Work out the bearing of  $A$  from  $P$ .

..... 270 °  
(1)

(Total for Question 1 is 2 marks)

2

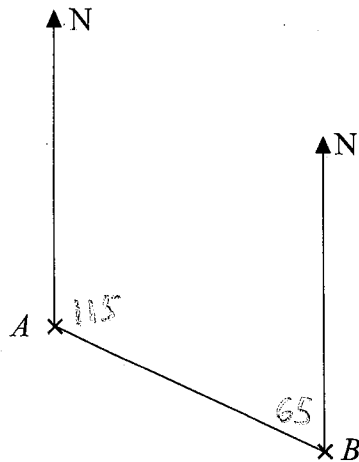

(a) Measure the bearing of  $B$  from  $A$ .

..... 115 °  
(1)

(b) Measure the bearing of  $A$  from  $B$ .

$360 - 65$

..... 295 °  
(1)

(Total for Question 2 is 2 marks)

3 The accurate scale drawing shows the positions of boat *A* and boat *B*.

Boat *C* is on a bearing of  $065^\circ$  from *A*.

Boat *C* is on a bearing of  $315^\circ$  from *B*.

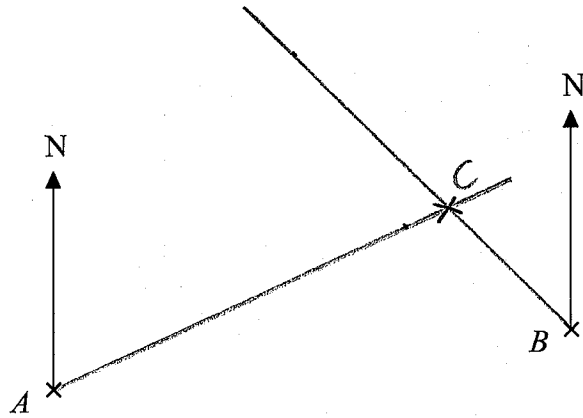

On the diagram, mark with a cross (x) the position of boat *C* on the diagram.

**(Total for Question 3 is 2 marks)**

4 The accurate scale drawing shows the positions of boat *A* and boat *B*.

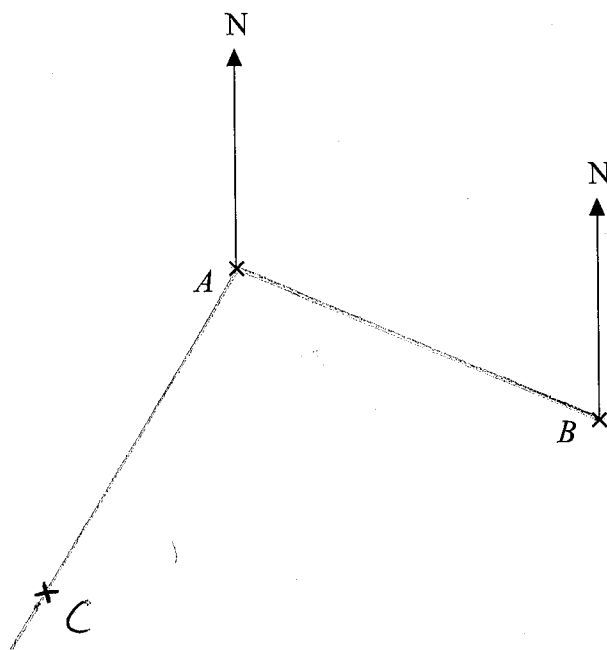

**Scale**  
2 cm represents 1 km

(a) Find the distance from *A* to *B*.

5.2 cm

$$5.2 \div 2 = 2.6$$

2.6

km

(1)

(b) Measure the bearing of *B* from *A*.

113

°

(1)

Another boat *C* is 2.5 km from *A* on a bearing of  $210^\circ$

(c) On the diagram, mark the position of boat *C* with a cross (×).

(2)

$$2.5 \text{ km} = 5 \text{ cm}$$

**(Total for Question 4 is 4 marks)**

5 The accurate scale drawing shows the positions of point  $A$  and point  $B$ .

Point  $C$  is 8 cm from point  $A$  on a bearing of  $070^\circ$

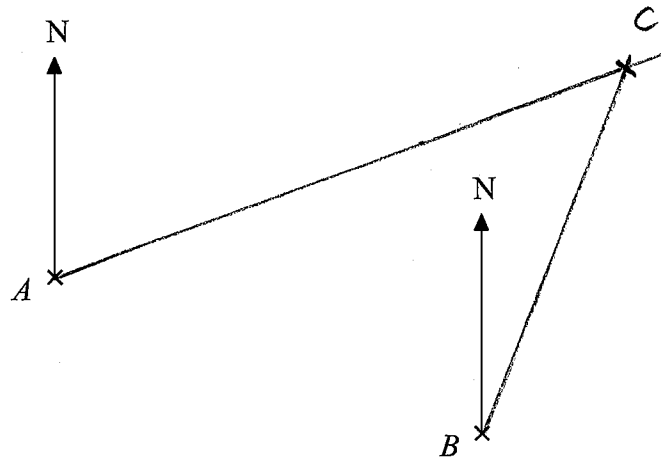

(a) Find the distance from  $B$  to  $C$ .

5.2 cm

5.2 cm  
.....  
(2)

(b) Find the bearing of  $C$  from  $B$ .

022  
.....  
(2)

**(Total for Question 5 is 4 marks)**

- 6 The accurate scale drawing shows the positions of point *A* and point *B*.  
1 cm represents 100 m.

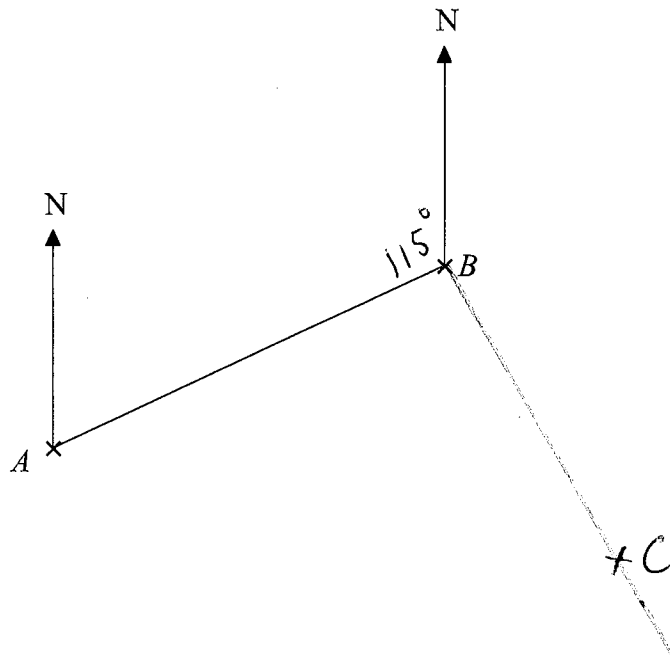

- (a) Find the bearing of *A* from *B*.

$$360 - 115$$

$$\underline{245}^{\circ}$$

(1)

Point *C* is 450 m from *B* on a bearing of  $150^{\circ}$

- (b) Draw point *C*, with a cross ( $\times$ ), on the diagram.

(2)

**(Total for Question 6 is 3 marks)**

- 7 The accurate scale drawing shows the positions of two towns, town *A* and town *B*.  
2 cm represents 1 km.

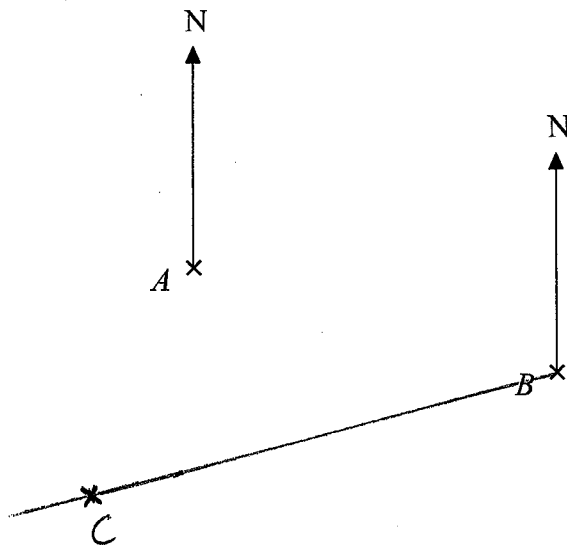

- (a) Find the real distance between town *A* and town *B*.

$$5 \text{ cm} = 2.5 \text{ km}$$

$$2.5 \text{ km}$$

(1)

Town *C* is 3.2 km from *B* on a bearing of  $255^\circ$

- (b) Draw the position of town *C*, with a cross ( $\times$ ), on the diagram.

(2)

$$3.2 \text{ km} = 6.4 \text{ cm}$$

$$360 - 255 = 105$$

(Total for Question 7 is 3 marks)

8 Oxford is on a bearing of  $330^\circ$  from Cambridge.

Find the bearing of Cambridge from Oxford.

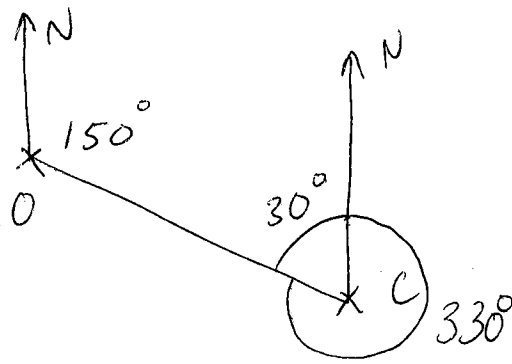

$$180 - 30 = 150^\circ$$

150 °

(Total for Question 8 is 2 marks)

9 The bearing of London from Liverpool is  $130^\circ$

Find the bearing of Liverpool from London.

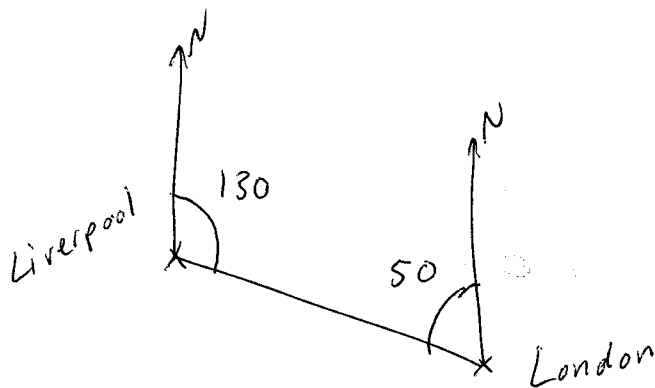

$$360 - 50 = 310^\circ$$

310 °

(Total for Question 9 is 2 marks)

Name: \_\_\_\_\_

GCSE (1 – 9)

## Loci and Construction

### Instructions

- Use **black** ink or ball-point pen.
- Answer all Questions.
- Answer the Questions in the spaces provided  
– *there may be more space than you need.*
- Diagrams are **NOT** accurately drawn, unless otherwise indicated.
- You must **show all your working out.**

### Information

- The marks for each Question are shown in brackets  
– *use this as a guide as to how much time to spend on each Question.*

### Advice

- Read each Question carefully before you start to answer it.
- Keep an eye on the time.
- Try to answer every Question.
- Check your answers if you have time at the end

1  $ABC$  is a triangle.

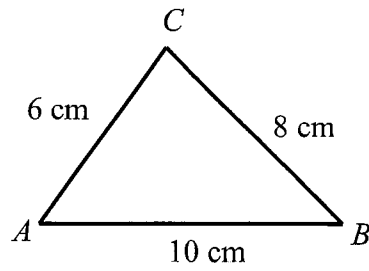

$$AB = 10\text{ cm}$$

$$BC = 8\text{ cm}$$

$$AC = 6\text{ cm}$$

Use ruler and compasses to construct an accurate drawing of triangle  $ABC$ .

You must show all your construction lines.

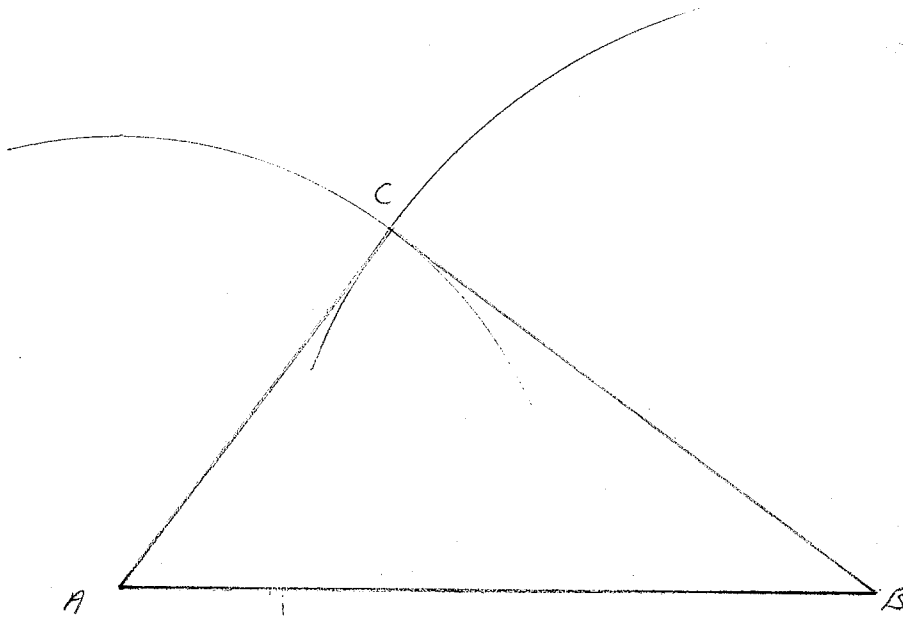

---

(Total for Question 1 is 3 marks)

- 2 A stadium is going to be built.  
It must be more than 10 km from town A and no more than 8 km from town B.

1 cm represents 2 km     5 cm                             4 cm

Shade the region on the diagram where the stadium can be built.

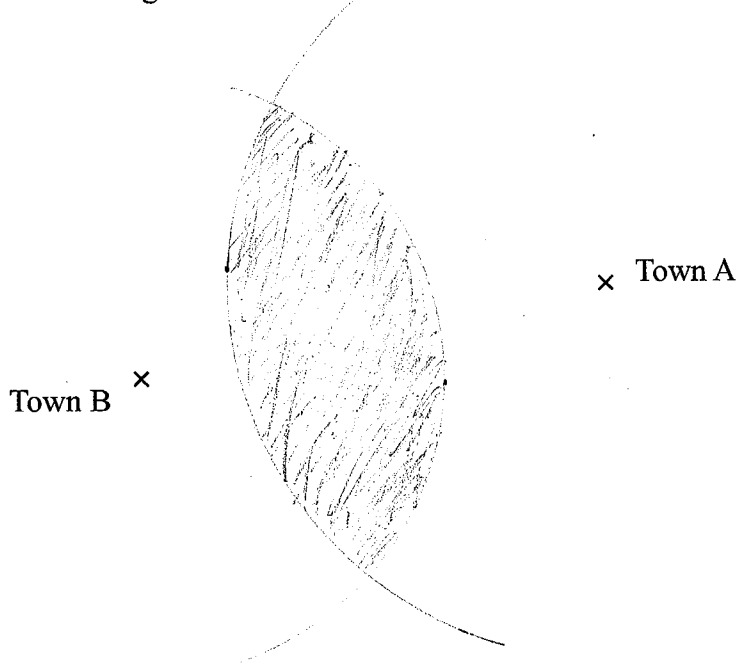

(Total for Question 2 is 2 marks)

- 3 In the space below, use a ruler and compasses to construct an equilateral triangle with side length 6 cm.

You must show all your construction lines.

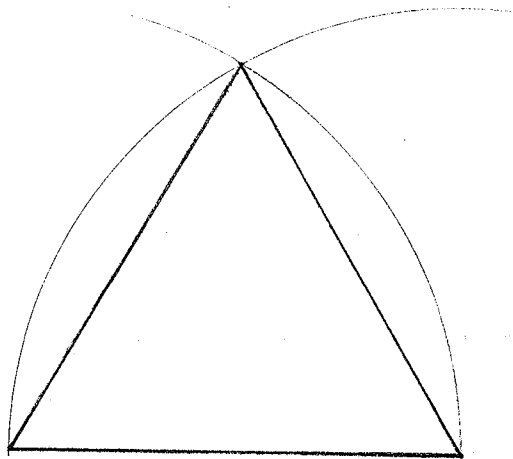

(Total for Question 3 is 3 marks)

- 4 Use ruler and compasses to construct the perpendicular from point  $C$  to the line  $AB$ .  
You must show all your construction lines.

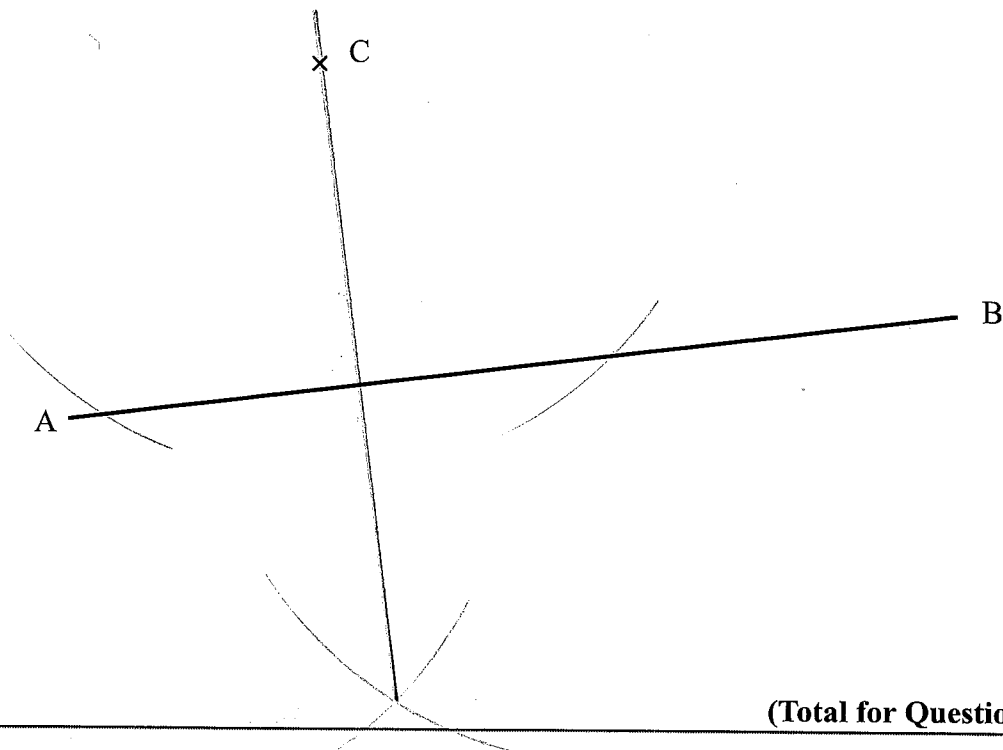

(Total for Question 4 is 2 marks)

- 5 Use ruler and compasses to construct the perpendicular from point  $P$  to the line  $AB$ .  
You must show all your construction lines.

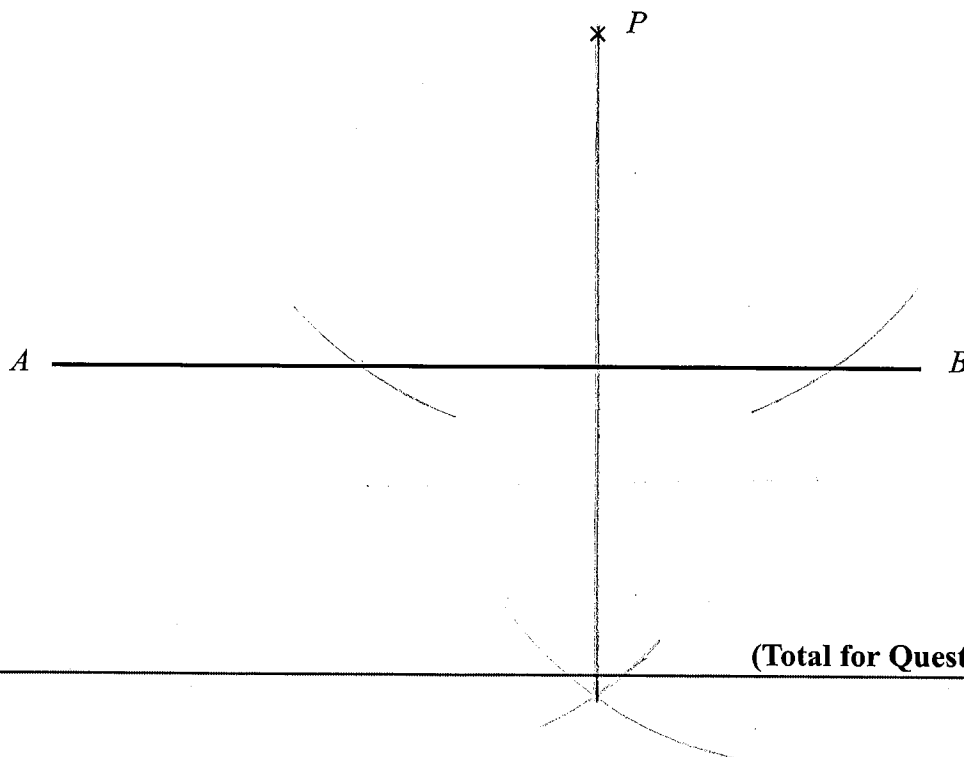

(Total for Question 5 is 2 marks)

- 6 Use ruler and compasses to construct the bisector of angle  $BAC$ .  
You must show all your construction lines.

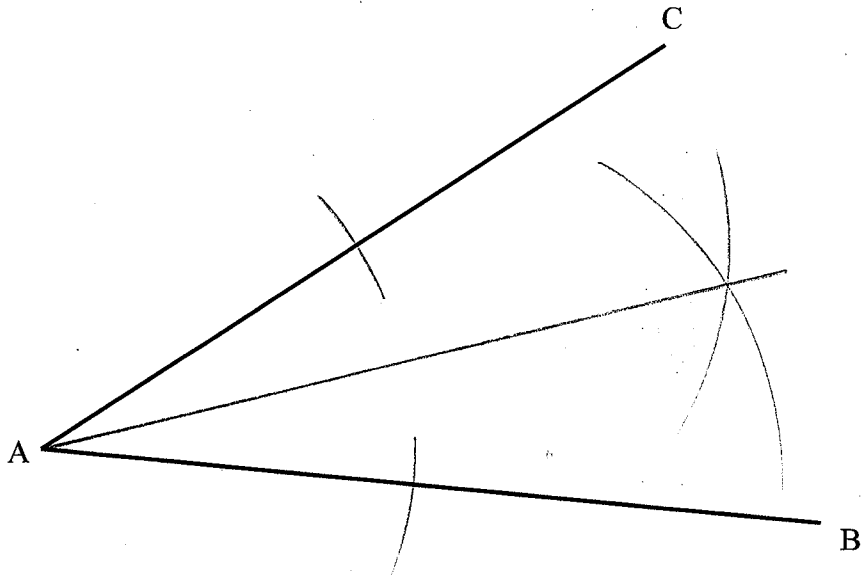

(Total for Question 6 is 2 marks)

- 7 Use ruler and compasses to construct the bisector of angle  $DEF$ .  
You must show all your construction lines.

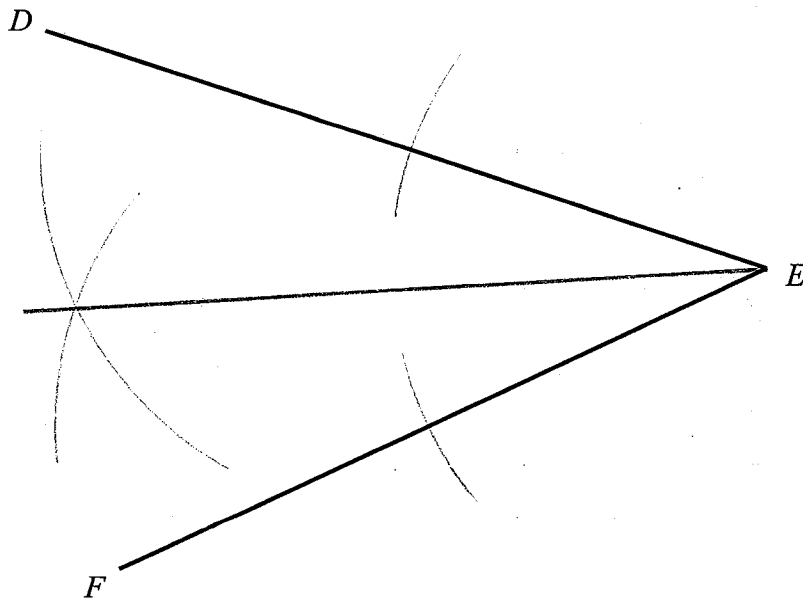

(Total for Question 7 is 2 marks)

- 8 Use ruler and compasses to construct a perpendicular bisector of the line  $AB$ .  
You must show all your construction lines.

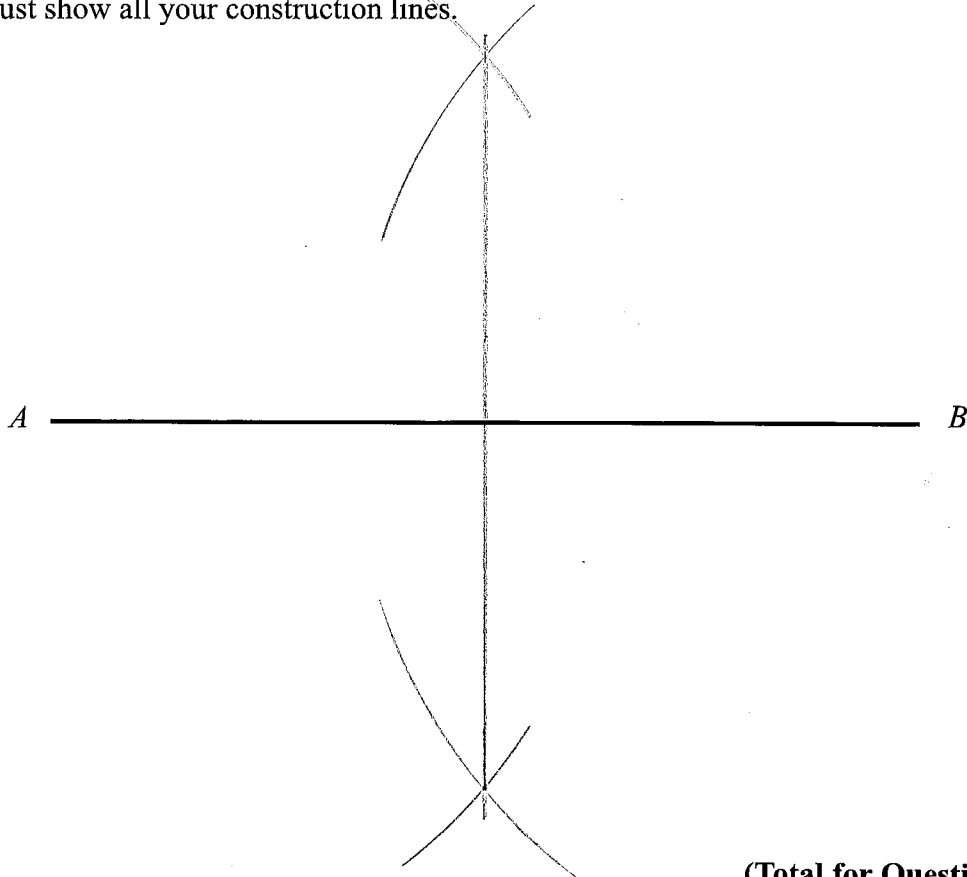

(Total for Question 8 is 2 marks)

- 9 In the space below, use a ruler and compasses to construct a  $30^\circ$  angle.  
You must show all your construction lines.

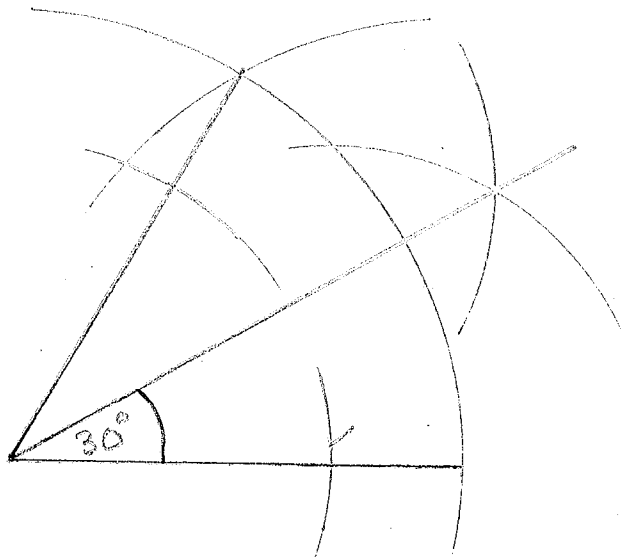

(Total for Question 9 is 4 marks)

- 10 Here is a scale drawing of a garden.  
The scale is 1 cm to 2 m

A tree is going to be planted.  
The tree must be more than 4 m from the patio.  
The tree must be more than 6 m from the pond.

Shade the region where the tree can be planted.

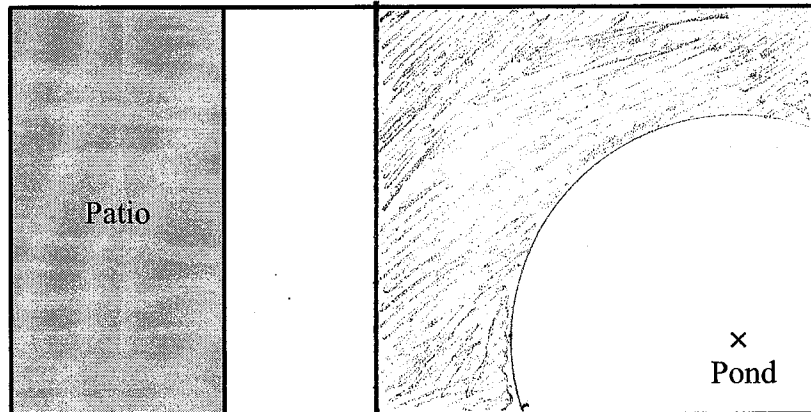

(Total for Question 10 is 2 marks)

- 11 Here is a scale drawing of a room.  
The scale is 1 cm to 2 m.

A chair is going to be placed in the room.  
The chair must be closer to  $AB$  than  $BC$ .  
The chair must be less than 14 m from  $D$ .

Shade the region where the chair can be placed.

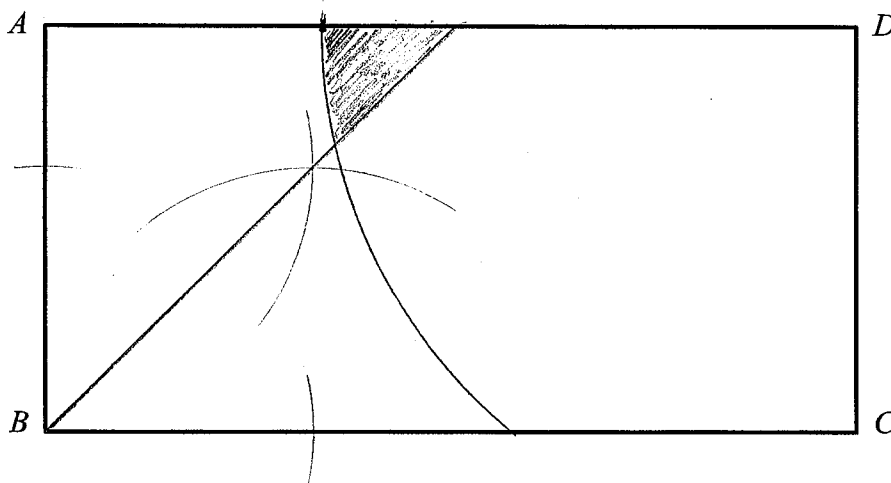

(Total for Question 11 is 2 marks)

12  $A$ ,  $B$  and  $C$  are three points on a map.

1 cm represents 100 metres.

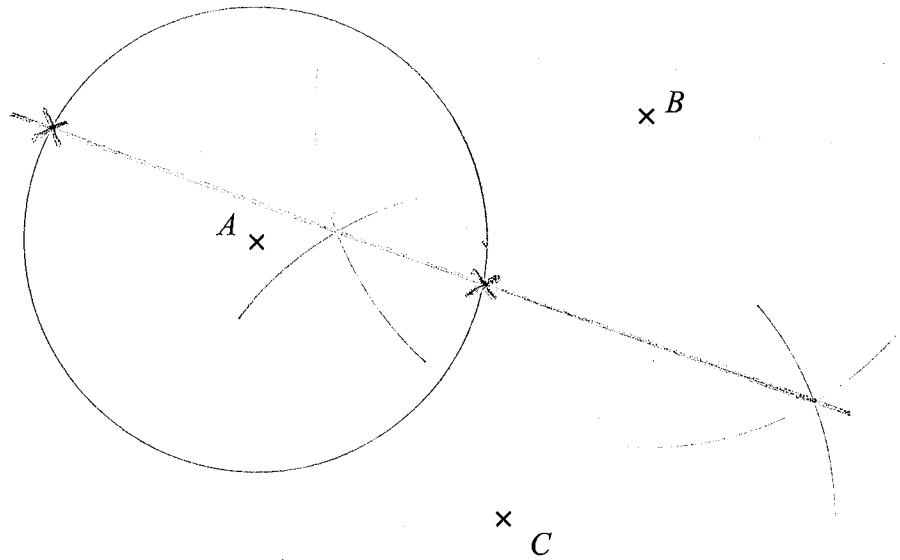

Point  $P$  is 300 metres from  $A$ .

Point  $P$  is equidistant from  $B$  and  $C$ .

On the map, show the possible positions of  $P$ .

**(Total for Question 12 is 3 marks)**

Name: \_\_\_\_\_

## GCSE (1 – 9)

### Cylinders

#### Instructions

- Use **black** ink or ball-point pen.
- Answer all Questions.
- Answer the Questions in the spaces provided  
– *there may be more space than you need.*
- Diagrams are **NOT** accurately drawn, unless otherwise indicated.
- You must **show all your working out.**

#### Information

- The marks for each Question are shown in brackets  
– *use this as a guide as to how much time to spend on each Question.*

#### Advice

- Read each Question carefully before you start to answer it.
- Keep an eye on the time.
- Try to answer every Question.
- Check your answers if you have time at the end

1 A cylinder has a radius of 5 cm and a height of 12 cm.

Work out the volume of the cylinder.  
Give your answer in terms of  $\pi$ .

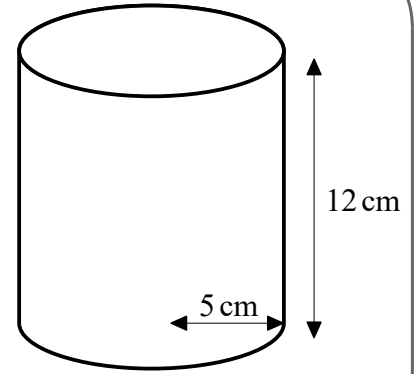

$$\begin{aligned}\text{volume} &= \text{area of circle} \times \text{height} \\ &= \pi r^2 \times h \\ &= \pi (5)^2 (12) \\ &= 300\pi \text{ cm}^3\end{aligned}$$

$$\dots\dots\dots 300\pi \dots\dots\dots \text{cm}^3$$

(Total for Question 1 is 3 marks)

2 A cylinder has a diameter of 9 cm and a height of 11 cm.

Work out the volume of the cylinder.  
Give your answer correct to 1 decimal place.

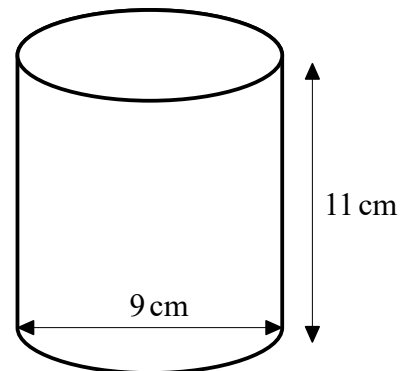

$$\begin{aligned}\text{radius} &= \frac{9}{2} = 4.5 \text{ cm} \\ \text{volume} &= \pi (4.5)^2 (11) \\ &= 699.8 \text{ cm}^3\end{aligned}$$

$$\dots\dots\dots 699.8 \dots\dots\dots \text{cm}^3$$

(Total for Question 2 is 3 marks)

3 A solid cylinder has a radius of 4 cm and a height of 10.5 cm.

Work out the total surface area of the cylinder.

Give your answer correct to 1 decimal place.

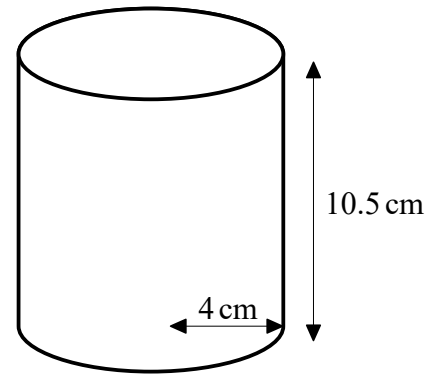

2 circles + circumference x height

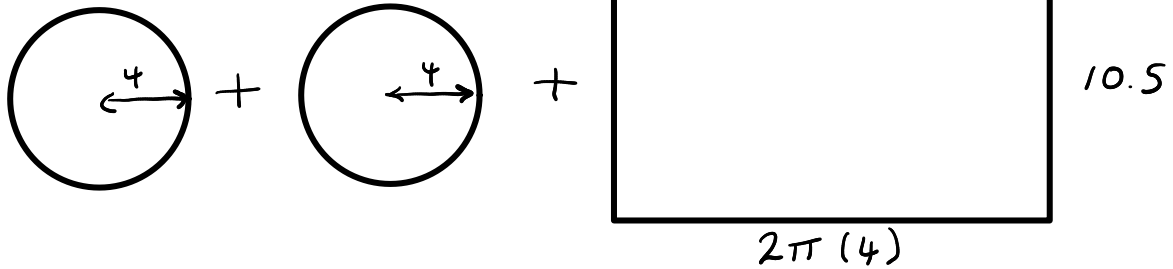

$$\pi(4)^2 + \pi(4)^2 + 2\pi(4) \times 10.5$$

$$364.4 \text{ cm}^2$$

$$\dots\dots\dots 364.4 \dots\dots\dots \text{cm}^2$$

(Total for Question 3 is 3 marks)

4 A solid cylinder has a diameter of 7 cm and a height of 15 cm.

Work out the total surface area of the cylinder.

Give your answer correct to 3 significant figures.

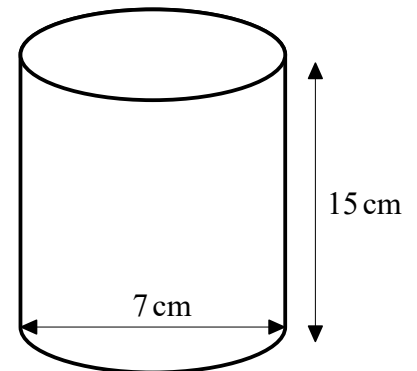

$$r = 3.5 \text{ cm}$$

$$2\pi r^2 + 2\pi r h$$

$$2\pi(3.5)^2 + 2\pi(3.5)(15)$$

$$\underline{\underline{407 \text{ cm}^2}}$$

$$\dots\dots\dots 407 \dots\dots\dots \text{cm}^2$$

(Total for Question 4 is 3 marks)

5 A solid cylinder has a radius of 6 m and a height of 7 m.

Work out the total surface area of the cylinder.

Give your answer in terms of  $\pi$ .

$$2\pi r^2 + 2\pi r \times h$$

$$2\pi(6)^2 + 2\pi(6) \times 7$$

$$156\pi \text{ m}^2$$

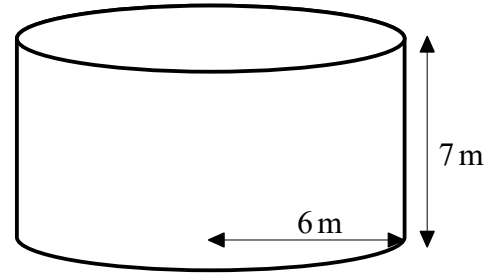

$$\dots\dots\dots 156\pi \text{ m}^2 \dots\dots\dots$$

(Total for Question 5 is 4 marks)

6 A solid cylinder has a radius of 14 cm and a height of 25 cm.

Work out the volume of the cylinder.

Give your answer correct to 3 significant figures.

$$\text{volume} = \text{area of circle} \times \text{height}$$

$$= \pi(14)^2 \times 25$$

$$= 15400 \text{ cm}^3$$

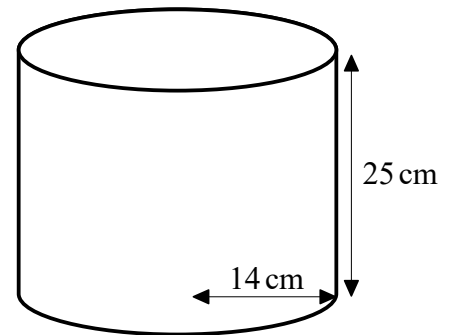

$$\dots\dots\dots 15400 \text{ cm}^3 \dots\dots\dots$$

(Total for Question 6 is 4 marks)

7

A solid cylinder is cut in half to form a semi-cylinder with a radius of 20 cm and a length of 75 cm.

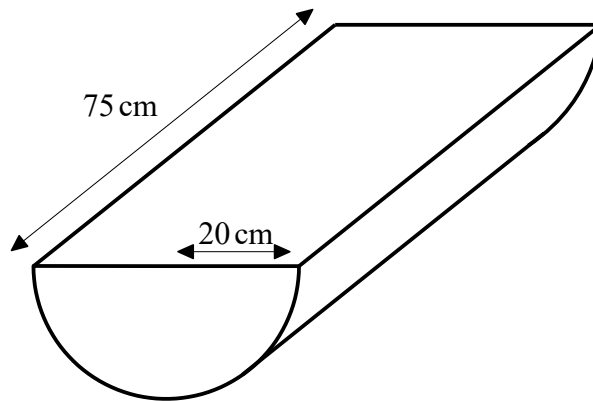

- (a) Work out the volume of the semi-cylinder.  
Give your answer correct to 3 significant figures.

$$\begin{aligned} \text{Volume} &= \text{area of semi-circle} \times \text{length} \\ &= \frac{\pi(20)^2}{2} \times 75 \\ &= 47100 \text{ cm}^3 \end{aligned}$$

$$\underline{\underline{47100}} \text{ cm}^3 \quad (3)$$

- (b) Work out the total surface area of the semi-cylinder.  
Give your answer correct to 3 significant figures.

$$\text{Area of semi circle} = \frac{\pi(20)^2}{2} = 200\pi$$

$$\text{half of circumference} = \frac{2\pi(20)}{2} = 20\pi$$

$$\text{Diagram} + \text{Diagram} + \text{top} + \text{curved face}$$

$$200\pi + 200\pi + 40 \times 75 + 20\pi \times 75$$

$$8969.0 \text{ cm}^2$$

$$\underline{\underline{8970}} \text{ cm}^2 \quad (3)$$

(Total for Question 7 is 6 marks)

8

A solid is formed by placing a half cylinder on a rectangular prism.  
The solid has a width of 2 m, a total height of 3 m and a length of 8 m.

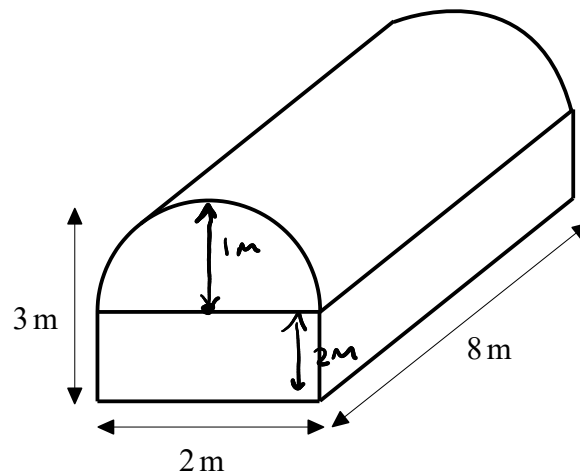

Work out the volume of the solid.  
Give your answer correct to 3 significant figures.

$$\text{radius} = 1\text{ m}$$

$$\text{Area of semi circle} = \frac{\pi (1)^2}{2} = \frac{\pi}{2}$$

$$\begin{aligned} \text{Area of cross section} &= 2 \times 2 + \frac{\pi}{2} \\ &= 5.57 \text{ m}^2 \end{aligned}$$

$$\begin{aligned} \text{volume} &= 5.57 \times 8 \\ &= 44.566 \text{ m}^3 \\ &= 44.6 \text{ m}^3 \end{aligned}$$

.....44.6.....m<sup>3</sup>  
(Total for Question 8 is 4 marks)

- 9 A solid cylinder has a radius of  $r$  m and a height of 12 m.  
The volume of the cylinder is  $507\pi$  m<sup>3</sup>.  
Find the value of  $r$ .

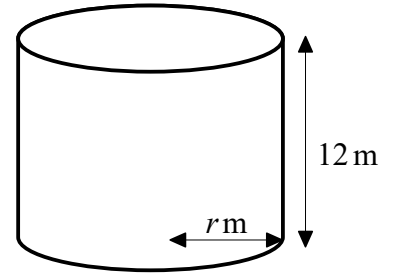

$$\cancel{\pi} r^2 \times 12 = 507 \cancel{\pi}$$

$$12r^2 = 507$$

$$r^2 = \frac{507}{12}$$

$$r^2 = 42.25$$

$$r = \sqrt{42.25}$$

$$= 6.5 \text{ m}$$

$$r = \dots 6.5 \dots$$

(Total for Question 9 is 4 marks)

- 10 A solid cylinder has a radius of 5 m and a height of  $h$  m.  
The total surface area of the cylinder is  $165\pi$  m<sup>2</sup>.  
Find the value of  $h$ .

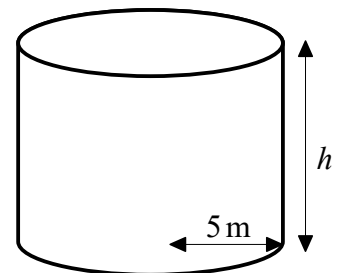

$$2\pi r^2 + 2\pi r h = 165\pi$$

$$2\pi(5)^2 + 2\pi(5)h = 165\pi$$

$$50\pi + 10\pi h = 165\pi$$

$$10 \cancel{\pi} h = 115 \cancel{\pi}$$

$$10h = 115$$

$$h = 11.5 \text{ m}$$

$$h = \dots 11.5 \dots$$

(Total for Question 10 is 4 marks)

- 11 The diagram shows a cylindrical tank.  
The tank has a top and a bottom.

5 of these tanks are going to be painted.  
Each tank has a diameter of 40 cm and a height of 1.8 m.

Each pot of paint can cover  $4 \text{ m}^2$ .

How many pots of paint are needed to paint the 5 tanks?

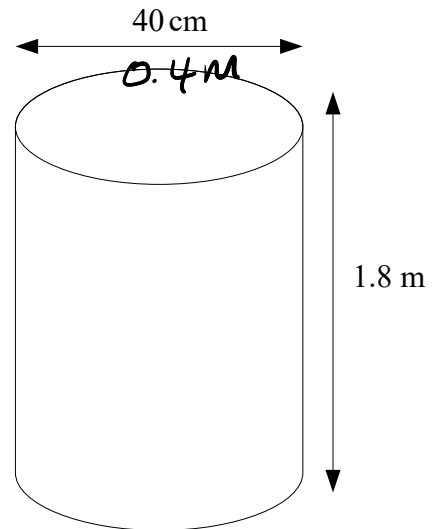

$$r = 0.2 \text{ m}$$

$$\text{Area of circle} = \pi (0.2)^2$$

$$\text{circumference} = 0.4 \pi$$

$$\text{surface area} = 2 \pi (0.2)^2 + 0.4 \pi (1.8)$$

$$= \frac{4}{5} \pi$$

$$= 2.51 \text{ m}^2$$

$$5 \text{ tanks} \quad 2.51 \times 5 = 12.6 \text{ m}^2$$

$$\frac{12.6}{4} = 3.14 \text{ pots of paint}$$

4 pots are needed

.....4.....pots  
(Total for Question 11 is 4 marks)

12 A cylinder has a diameter of 9 cm and a height of 11 cm.

- (a) Work out the volume of the cylinder.  
Give your answer correct to 1 decimal place.

$$r = 4.5$$

$$\begin{aligned} \text{volume} &= \pi (4.5)^2 \times 11 \\ &= \underline{\underline{699.8 \text{ cm}^3}} \end{aligned}$$

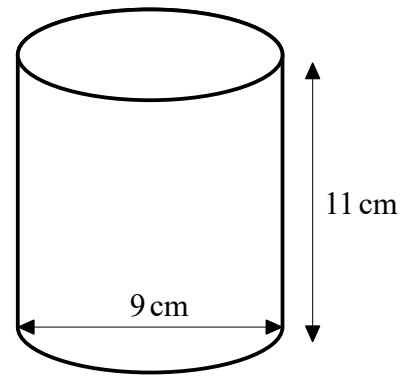

$$\underline{\underline{699.8}} \text{ cm}^3$$

(3)

- (b) The volume of another cylinder is  $1500 \text{ cm}^2$ .  
Michael says that  $1500 \text{ cm}^2$  is the same as  $15 \text{ m}^2$ .

Is Michael correct?

You must give a reason for your answer.

$$\begin{aligned} 1 \text{ m}^2 &= \begin{array}{c} \square \\ \text{100 cm} \quad \text{100 cm} \end{array} \\ &= 100 \times 100 \\ &= 10000 \text{ cm}^2 \end{aligned}$$

No.

$15 \text{ m}^2$  is the same as  $150000 \text{ cm}^2$

(1)

(Total for Question 12 is 4 marks)

- 13 The diagram shows an empty tank in the shape of a cylinder.

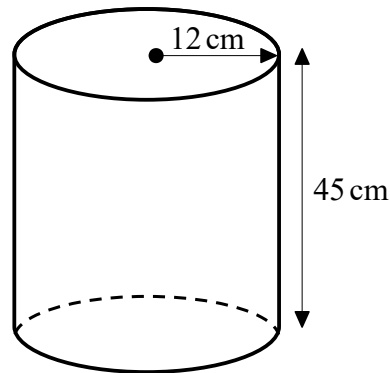

The cylinder has radius 12 cm and height 45 cm.

Water flows into the tank at a rate of 1.8 litres per minute.

Calculate the number of minutes it will take to completely fill the tank.  
Give your answer correct to the nearest minute.

$$\begin{aligned} \text{volume} &= \pi (12)^2 (45) \\ &= 20357.5 \text{ cm}^3 \end{aligned}$$

$$1000 \text{ cm}^3 = 1 \text{ litre}$$

$$\text{volume} = 20.3575 \text{ litres}$$

$$\frac{20.3575}{1.8} = 11.3 \text{ minutes}$$

..... 11 ..... minutes

(Total for Question 13 is 4 marks)

Name: \_\_\_\_\_

## GCSE (1 – 9)

# Volume of Prisms

### Instructions

- Use **black** ink or ball-point pen.
- Answer all Questions.
- Answer the Questions in the spaces provided  
– *there may be more space than you need.*
- Diagrams are **NOT** accurately drawn, unless otherwise indicated.
- You must **show all your working out.**

### Information

- The marks for each Question are shown in brackets  
– *use this as a guide as to how much time to spend on each Question.*

### Advice

- Read each Question carefully before you start to answer it.
- Keep an eye on the time.
- Try to answer every Question.
- Check your answers if you have time at the end

1

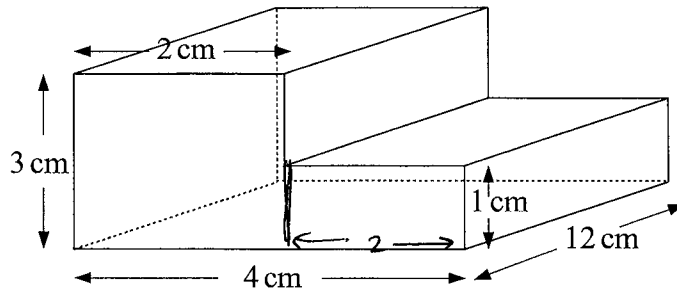

The diagram shows a prism.

Work out the volume of the prism.

$$\begin{aligned} \text{Area of cross section} &= 3 \times 2 + 2 \times 1 \\ &= 6 + 2 \\ &= 8 \text{ cm}^2 \end{aligned}$$

$$\begin{aligned} \text{Volume} &= 8 \times 12 \\ &= 96 \text{ cm}^3 \end{aligned}$$

.....96.....cm<sup>3</sup>

(Total for question 1 is 3 marks)

2

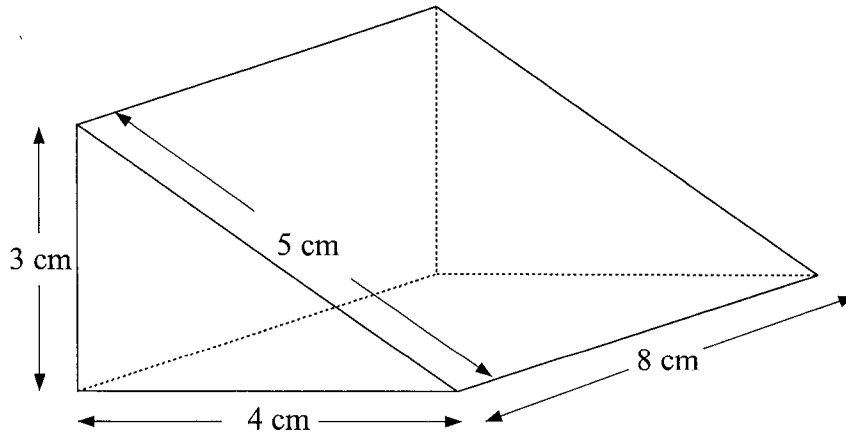

The diagram shows a triangular prism.

The cross-section of the prism is a right angled triangle.

Calculate the volume of the prism.

$$\text{Area of cross section} = \frac{3 \times 4}{2} = 6 \text{ cm}^2$$

$$\begin{aligned} \text{Volume} &= 6 \times 8 \\ &= 48 \text{ cm}^3 \end{aligned}$$

.....48.....cm<sup>3</sup>

(Total for question 2 is 3 marks)

3

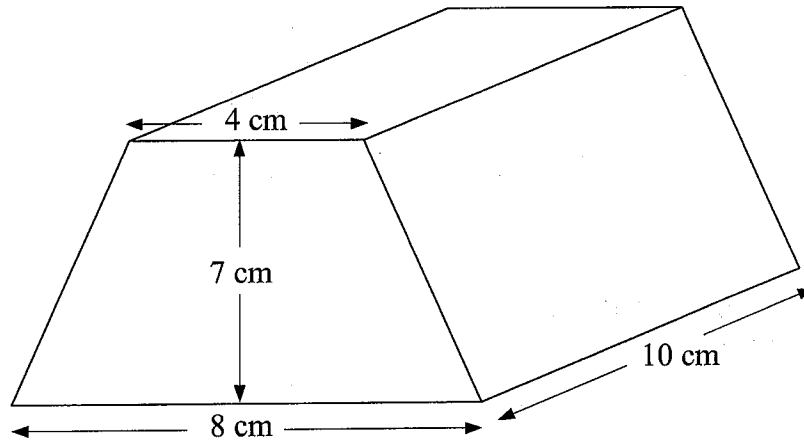

The diagram shows a prism.  
The cross-section of the prism is a trapezium.

Work out the volume of the prism.

$$\begin{aligned} \text{Area of cross section} &= \frac{1}{2}(4+8) \times 7 \\ &= 6 \times 7 \\ &= 42 \text{ cm}^2 \end{aligned}$$

$$\begin{aligned} \text{Volume} &= 42 \times 10 \\ &= 420 \text{ cm}^3 \end{aligned}$$

.....420.....cm<sup>3</sup>  
(Total for question 3 is 3 marks)

4

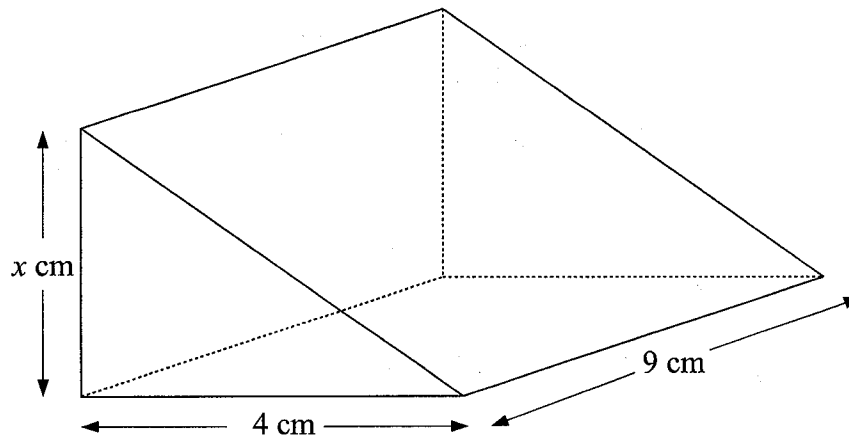

The diagram shows a triangular prism.  
The cross-section of the prism is a right angled triangle.

The volume of the prism is  $198 \text{ cm}^3$

Calculate the value of  $x$     Area of cross section =  $\frac{4x}{2} = 2x$

$$\text{Volume} = 2x \times 9 = 18x$$

$$18x = 198$$

$$x = \frac{198}{18} = \frac{99}{9} = 11 \text{ cm}$$

.....11.....  
(Total for question 4 is 3 marks)

5

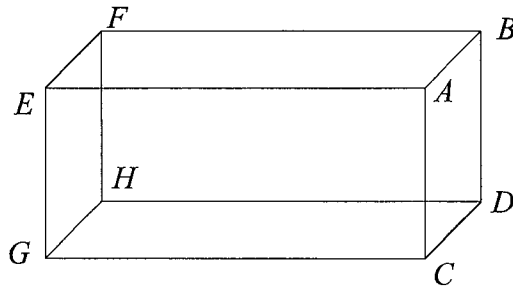

The diagram shows a cuboid  $ABCDEFGH$   
 $ABCD$  is a square with area  $25\text{cm}^2$ .  
 $CG = 12\text{ cm}$ .

Find the volume of the cuboid.

$$\begin{aligned} \text{Volume} &= 25 \times 12 \\ &= 300\text{ cm}^3 \end{aligned}$$

..... $300$ ..... $\text{cm}^3$

(Total for question 5 is 2 marks)

- 6 Bob has a van.  
 He is using the van to deliver boxes.  
 Each box is a cuboid, 60 cm by 30 cm by 40 cm.

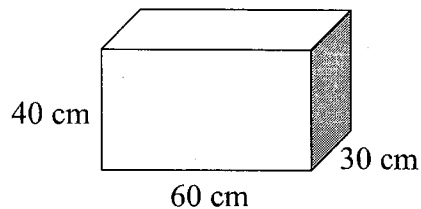

The van has the space for the boxes in the shape of a cuboid with:

length 3 m     $300\text{ cm}$   
 width 1.8 m     $180\text{ cm}$   
 height 2 m     $200\text{ cm}$

Work out how many boxes can Bob fit into the van.

$$\text{Length} \quad \frac{300}{60} = 5$$

$$\text{Width} \quad \frac{180}{30} = 6$$

$$\text{Height} \quad \frac{200}{40} = 5$$

$$\begin{aligned} \text{Total boxes} &= 5 \times 6 \times 5 \\ &= 150 \end{aligned}$$

..... $150$ .....

(Total for question 6 is 3 marks)

- 7 The diagram shows a cuboid.

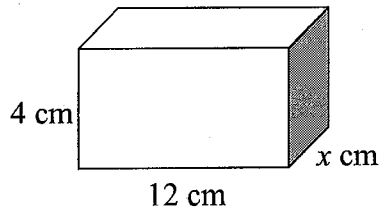

The volume of the cuboid is  $120 \text{ cm}^3$

Calculate the value of  $x$

$$\text{Area of cross section} = 4 \times 12 = 48 \text{ cm}^2$$

$$\text{Volume} = 48x$$

$$48x = 120$$

$$x = \frac{120}{48} = \frac{60}{24} = \frac{30}{12} = \frac{15}{6} = \frac{5}{2} = 2.5$$

(Total for question 7 is 2 marks)

- 8 The diagram shows an empty water container.

Fiona is going to use a bucket to fill the container.  
Each bucket can hold 12 litres of water.

How many buckets of water will be needed to fill the container?

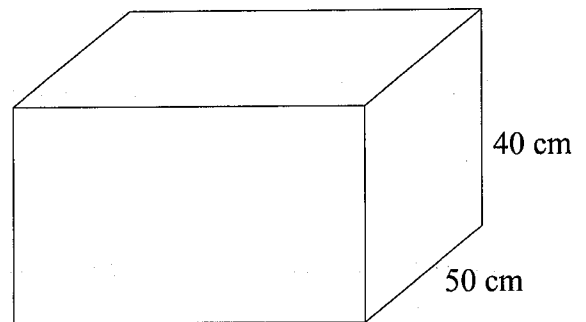

$$\begin{aligned} \text{Area of cross section} &= 90 \times 50 \\ &= 4500 \text{ cm}^2 \end{aligned}$$

$$\begin{aligned} \text{Volume} &= 4500 \times 40 \\ &= 180000 \text{ cm}^3 \end{aligned}$$

$$\boxed{1 \text{ Litre} = 1000 \text{ cm}^3}$$

$$\text{Volume} = 180 \text{ Litres}$$

$$\frac{180}{12} = \frac{90}{6} = \frac{45}{3} = 15$$

15

(Total for question 8 is 4 marks)

9 Here is a cube.

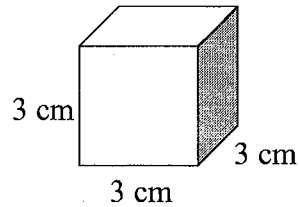

Work out the volume of five of these cubes.

$$V = 3 \times 3 \times 3 \\ = 27 \text{ cm}^3$$

$$27 \times 5 = 135$$

.....135.....cm<sup>3</sup>

(Total for question 9 is 2 marks)

10 The diagram shows an empty water container.

The container is going to be filled using a hose pipe.

The water will flow into the container at a rate of 2 litres per second.

How long will it take for the container to be filled completely?

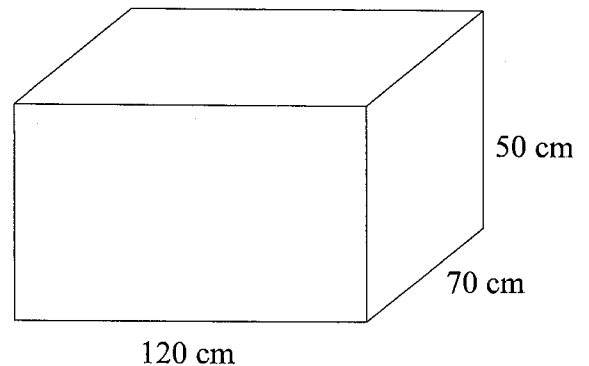

$$\text{volume} = 120 \times 70 \times 50 \\ = 8400 \times 50 \\ = 420000 \text{ cm}^3$$

$$\boxed{1000 \text{ cm}^3 = 1 \text{ Litre}}$$

$$= 420 \text{ litres}$$

$$\frac{420}{2} = 210 \text{ seconds}$$

.....210.....

(Total for question 10 is 4 marks)

11 The total surface area of a cube is  $150 \text{ cm}^2$ .

Work out the volume of the cube.

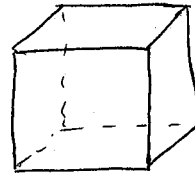

$$\frac{150}{6} = 25 \text{ cm}^2 \text{ each face } \& \text{ 6 faces}$$

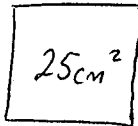

$$\sqrt{25} = 5 \text{ cm}$$

$$\begin{aligned} \text{volume} &= 5 \times 5 \times 5 \\ &= 125 \text{ cm}^3 \end{aligned}$$

..... 125 .....  $\text{cm}^3$

(Total for question 11 is 4 marks)

12 The diagram shows a water container.

The container is  $\frac{2}{3}$  full with water.

The water is going to be used to fill cups.  
Each cup holds 175 ml of water.

How many cups of water can be completely filled with water from the container

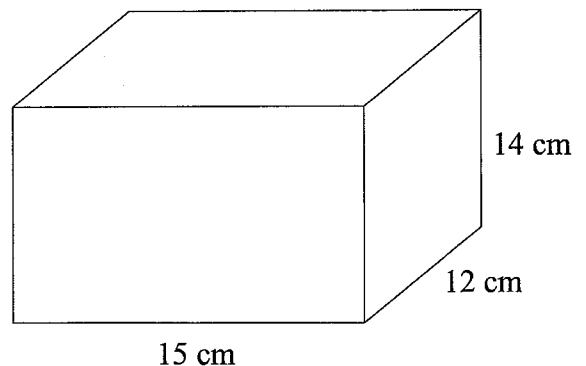

$$\begin{aligned} \text{volume} &= 15 \times 12 \times 14 \\ &= 180 \times 14 \\ &= 2520 \text{ cm}^3 \end{aligned}$$

$$\begin{array}{r} 180 \times 10 = 1800 \\ 180 \times 4 = 720 \\ \hline 2520 \end{array}$$

$$\frac{2}{3} \quad \frac{2}{3} \times 2520 = \frac{5040}{3}$$

$$= 1680 \text{ cm}^3 \quad (\text{WATER})$$

$$= 1680 \text{ ml}$$

$$1750 \text{ ml} = 10 \text{ cups}$$

$$1575 \text{ ml} = 9 \text{ cups}$$

..... 9 .....

(Total for question 12 is 4 marks)

13 Here is a triangular prism.

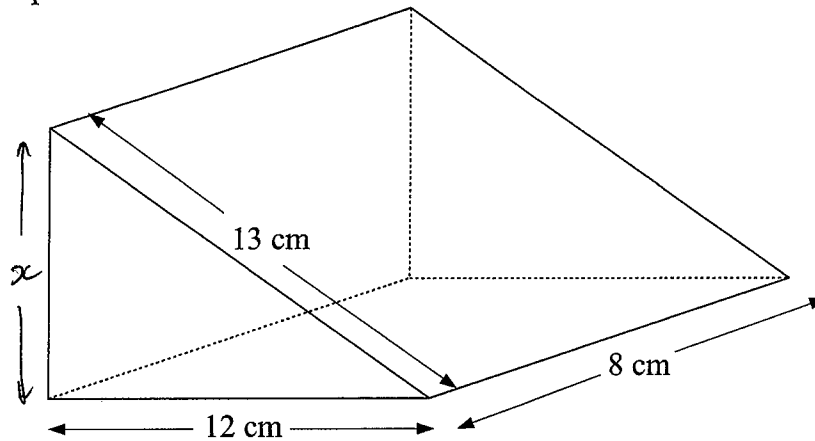

The diagram shows a triangular prism.  
The cross-section of the prism is a right angled triangle.

Calculate the volume of the prism.

$$\begin{aligned}x^2 + 12^2 &= 13^2 \\x^2 &= 13^2 - 12^2 \\x^2 &= 169 - 144 \\x^2 &= 25 \\x &= \sqrt{25} = 5\end{aligned}$$

$$\begin{aligned}\text{Area of cross section} &= \frac{5 \times 12}{2} \\&= 30 \text{ cm}^2\end{aligned}$$

$$\begin{aligned}\text{Volume} &= 30 \times 8 \\&= 240 \text{ cm}^3\end{aligned}$$

.....240.....cm<sup>3</sup>

(Total for question 13 is 5 marks)

Name: \_\_\_\_\_

GCSE (1 – 9)

Surface Area

### Instructions

- Use **black** ink or ball-point pen.
- Answer all Questions.
- Answer the Questions in the spaces provided  
– *there may be more space than you need.*
- Diagrams are **NOT** accurately drawn, unless otherwise indicated.
- You must **show all your working out.**

### Information

- The marks for each Question are shown in brackets  
– *use this as a guide as to how much time to spend on each Question.*

### Advice

- Read each Question carefully before you start to answer it.
- Keep an eye on the time.
- Try to answer every Question.
- Check your answers if you have time at the end

1 The diagram shows a cuboid..

Find the total surface area of the cuboid.

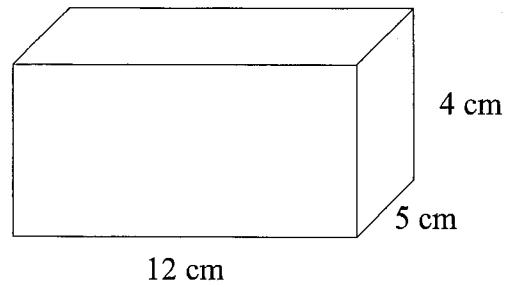

|        |                                 |
|--------|---------------------------------|
| Front  | $12 \times 4 = 48 \text{ cm}^2$ |
| Back   | $48 \text{ cm}^2$               |
| Top    | $12 \times 5 = 60 \text{ cm}^2$ |
| Bottom | $60 \text{ cm}^2$               |
| Side   | $5 \times 4 = 20 \text{ cm}^2$  |
| Side   | $20 \text{ cm}^2$               |

|       |
|-------|
| 48    |
| 48    |
| 60    |
| 60    |
| 20    |
| 20    |
| <hr/> |
| 256   |

.....  
 $256 \text{ cm}^2$

**(Total for question 1 is 3 marks)**

- 2 The diagram shows a triangular prism.  
Find the total surface area of the triangular prism.

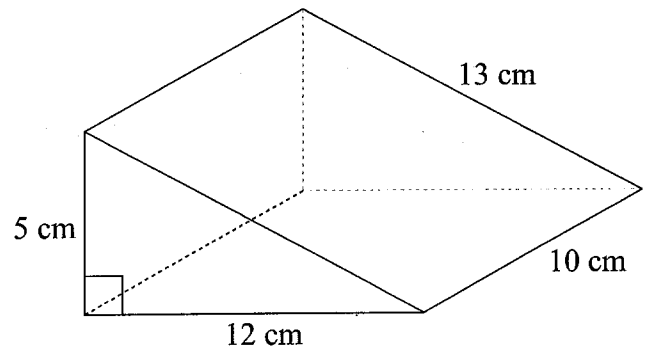

$$\begin{aligned} \text{Front} &= \frac{1}{2} \times 12 \times 5 = 30 \text{ cm}^2 \\ \text{Back} &= 30 \text{ cm}^2 \\ \text{Bottom} &= 12 \times 10 = 120 \text{ cm}^2 \\ \text{Side} &= 5 \times 10 = 50 \text{ cm}^2 \\ \text{Top} &= 13 \times 10 = 130 \text{ cm}^2 \end{aligned}$$

$$\begin{array}{r} 130 \\ 120 \\ 50 \\ 30 \\ 30 \\ \hline 360 \end{array}$$

$$\underline{\underline{360 \text{ cm}^2}}$$

(Total for question 2 is 3 marks)

3 The diagram shows a triangular prism.

Find the total surface area of the triangular prism.

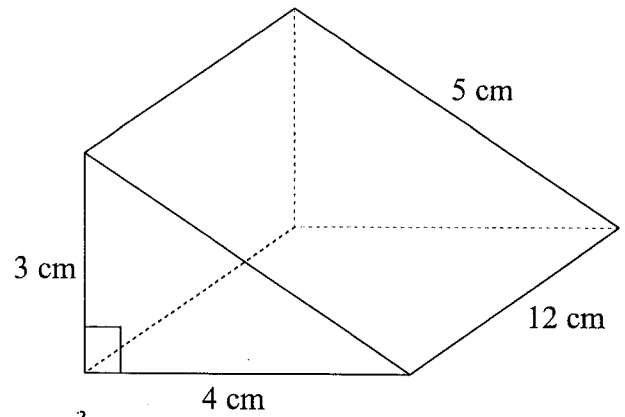

$$\text{Front} = \frac{1}{2} \times 4 \times 3 = 6 \text{ cm}^2$$

$$\text{Back} = 6 \text{ cm}^2$$

$$\text{Bottom} = 4 \times 12 = 48 \text{ cm}^2$$

$$\text{Side} = 3 \times 12 = 36 \text{ cm}^2$$

$$\text{Top} = 5 \times 12 = 60 \text{ cm}^2$$

$$\begin{array}{r} 60 \\ 48 \\ 36 \\ 6 \\ 6 \\ \hline 156 \end{array}$$

.....  $156 \text{ cm}^2$  .....

**(Total for question 3 is 3 marks)**

- 4 The diagram shows a prism.  
The cross section of the prism is in the shape of a trapezium.

Calculate the total surface area of the prism.

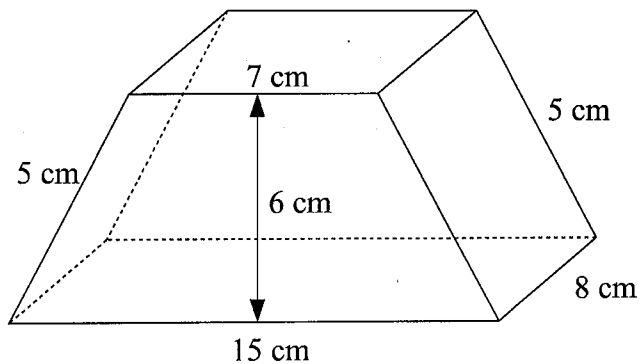

$$\begin{aligned}
 \text{Front} &= \frac{1}{2}(7 + 15) \times 6 = 66 \text{ cm}^2 \\
 \text{Back} &= 66 \text{ cm}^2 \\
 \text{Side} &= 5 \times 8 = 40 \text{ cm}^2 \\
 \text{Side} &= 40 \text{ cm}^2 \\
 \text{Top} &= 7 \times 8 = 56 \text{ cm}^2 \\
 \text{Bottom} &= 8 \times 15 = 120 \text{ cm}^2
 \end{aligned}$$

$$\begin{array}{r}
 1 \ 2 \ 0 \\
 6 \ 6 \\
 6 \ 6 \\
 5 \ 6 \\
 4 \ 0 \\
 4 \ 0 \\
 \hline
 2 \ 1 \\
 3 \ 8 \ 8
 \end{array}$$

$$\text{.....} 388 \text{ cm}^2 \text{.....}$$

(Total for question 4 is 4 marks)

5

The diagram shows a prism.

Calculate the total surface area of the prism.

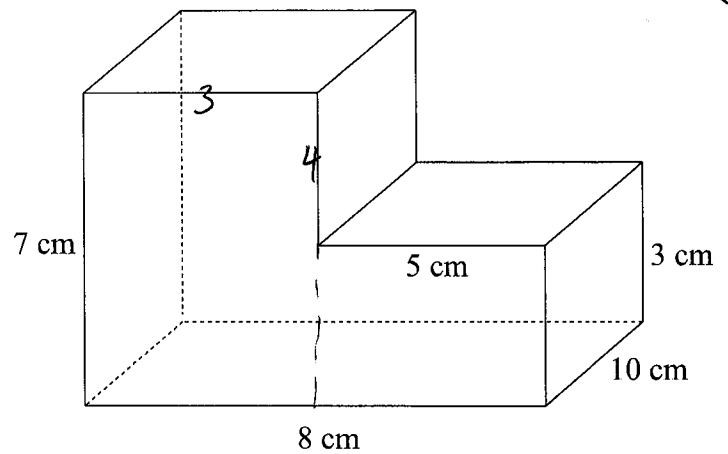

$$\text{Front} = 3 \times 7 + 5 \times 3 = 36 \text{ cm}^2$$

$$\text{Back} = 36 \text{ cm}^2$$

$$\text{Bottom} = 8 \times 10 = 80 \text{ cm}^2$$

$$\text{Total Top} = 80 \text{ cm}^2$$

$$\text{Side} = 7 \times 10 = 70 \text{ cm}^2$$

$$\text{Total Side} = 70 \text{ cm}^2$$

$$\begin{array}{r} 80 \\ 80 \\ 70 \\ 70 \\ 36 \\ 36 \\ \hline 372 \end{array}$$

$$\dots\dots\dots 372 \text{ cm}^2$$

(Total for question 5 is 4 marks)

6 The diagram shows a box.

5 of these boxes are going to be painted.

Each pot of paint can cover  $6\text{m}^2$ .

How many pots of paint are needed to paint the 5 boxes?

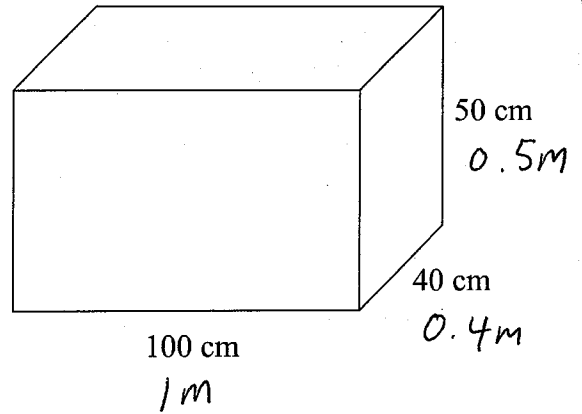

$$\text{Front} = 1 \times 0.5 = 0.5 \text{ m}^2$$

$$\text{Back} = \quad \quad \quad = 0.5 \text{ m}^2$$

$$\text{Side} = 0.4 \times 0.5 = 0.2 \text{ m}^2$$

$$\text{Side} \quad \quad \quad = 0.2 \text{ m}^2$$

$$\text{Top} = 1 \times 0.4 = 0.4 \text{ m}^2$$

$$\text{Bottom} = \quad \quad \quad = 0.4 \text{ m}^2$$

$$\begin{array}{r} 0.5 \\ 0.5 \\ 0.4 \\ 0.4 \\ 0.2 \\ 0.2 \\ \hline 2.2 \end{array}$$

$$2.2 \text{ m}^2 \times 5 = \underline{\underline{11 \text{ m}^2}} \text{ in total}$$

$$1 \text{ pot} = 6 \text{ m}^2$$

$$2 \text{ pots} = 12 \text{ m}^2$$

.....2.....pots

(Total for question 6 is 4 marks)

7

The diagram shows a cylindrical tank.  
The tank has a top and a bottom.

4 of these tanks are going to be painted.  
Each tank has a diameter of 50 cm and a height of 1.5 m.

Each pot of paint can cover  $4\text{ m}^2$ .

How many pots of paint are needed to paint the 4 tanks?

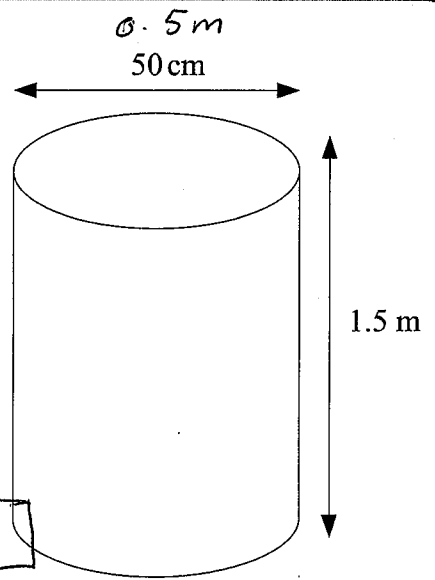

$$\text{Surface area} = \text{circle} + \text{circle} + \text{rectangle}$$

$$\begin{aligned} \text{Top} &= \pi r^2 = \pi (0.25)^2 \\ &= \frac{\pi}{16} \text{ OR } 0.1963495\dots \end{aligned}$$

$$\text{Radius} = 0.25\text{m}$$

$$\text{Bottom} = \frac{\pi}{16} \text{ OR } 0.1963495\dots$$

$$\begin{aligned} \text{Curved area} &= \text{circumference} \times 1.5 \\ &= \pi (0.5) \times 1.5 \\ &= \frac{3}{4} \pi \text{ OR } 2.35619\dots \end{aligned}$$

$$\begin{aligned} \text{Total surface area} &= \frac{1}{16} \pi + \frac{1}{16} \pi + \frac{3}{4} \pi \\ &= \frac{7}{8} \pi \text{ OR } 2.74889 \text{ m}^2 \end{aligned}$$

$$2.74889\dots \times 4 = \underline{10.99 \text{ m}^2} \quad [\text{surface area of 4 tanks}]$$

$$\frac{10.99}{4} = 2.74889 \quad \underline{3 \text{ pots needed}}$$

.....3.....pots

(Total for question 7 is 4 marks)

Name: \_\_\_\_\_

## GCSE (1 – 9)

# Angles in Polygons

### Instructions

- Use **black** ink or ball-point pen.
- Answer all Questions.
- Answer the Questions in the spaces provided  
– *there may be more space than you need.*
- Diagrams are **NOT** accurately drawn, unless otherwise indicated.
- You must **show all your working out.**

### Information

- The marks for each Question are shown in brackets  
– *use this as a guide as to how much time to spend on each Question.*

### Advice

- Read each Question carefully before you start to answer it.
- Keep an eye on the time.
- Try to answer every Question.
- Check your answers if you have time at the end

1 Work out the size of an exterior angle of a regular hexagon.

(Exterior angles always add to  $360^\circ$ )

$$\frac{360}{6} = 60$$

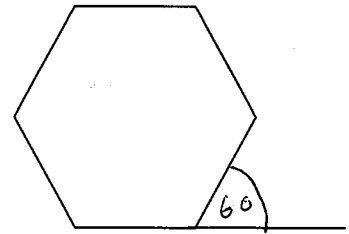

..... 60 .....

(Total for question 1 is 2 marks)

2 Work out the size of each interior angle in a regular octagon.

$$\frac{360}{8} = 45$$

$$180 - 45 = 135$$

(Interior angle + Exterior angle = 180)

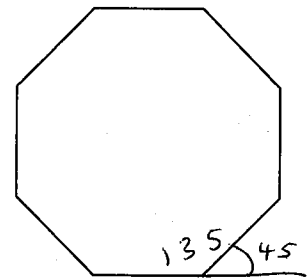

..... 135 .....

(Total for question 2 is 2 marks)

3 Work out the size of each interior angle in a regular pentagon

$$\frac{360}{5} = 72$$

$$180 - 72 = 108$$

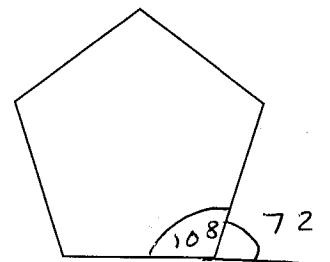

..... 108 .....

(Total for question 3 is 2 marks)

- 4 The size of each exterior angle in a regular polygon is  $20^\circ$ .  
Work out how many sides the polygon has.

$$\frac{360}{20} = \frac{36}{2} = 18$$

..... 18 .....

(Total for question 4 is 2 marks)

- 5 The size of each exterior angle in a regular polygon is  $18^\circ$ .  
Work out how many sides the polygon has.

$$\frac{360}{18} = \frac{180}{9} = 20$$

..... 20 .....

(Total for question 5 is 2 marks)

- 6 The size of each interior angle in a regular polygon is  $165^\circ$ .  
Work out how many sides the polygon has.

$$180 - 165 = 15 \quad (\text{Exterior angle} = 15^\circ)$$

$$\frac{360}{15} = \frac{120}{5} = 24$$

..... 24 .....

(Total for question 6 is 2 marks)

7

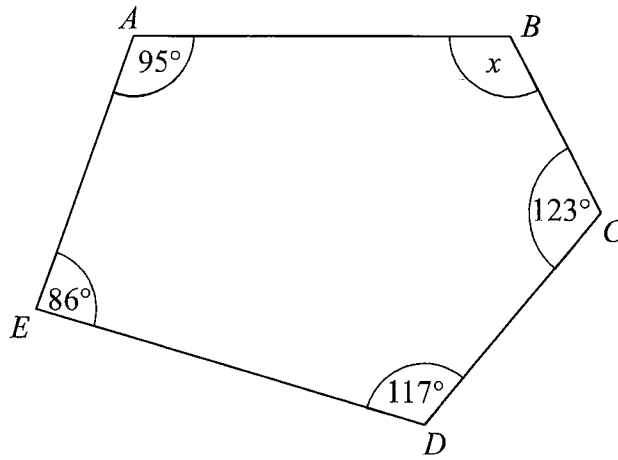

$$\begin{array}{r}
 123 \\
 117 \\
 95 \\
 + 86 \\
 \hline
 22 \\
 421
 \end{array}$$

ABCDE is a pentagon.

Work out the size of angle ABC.

$$\begin{aligned}
 \text{Angle sum} &= (n - 2) \times 180 \\
 &= (5 - 2) \times 180 \\
 &= 3 \times 180 \\
 &= 540
 \end{aligned}$$

$$\begin{aligned}
 540 - 421 \\
 = 119
 \end{aligned}$$

(Angles in a pentagon add to 540°)

.....119.....°

(Total for question 7 is 2 marks)

8

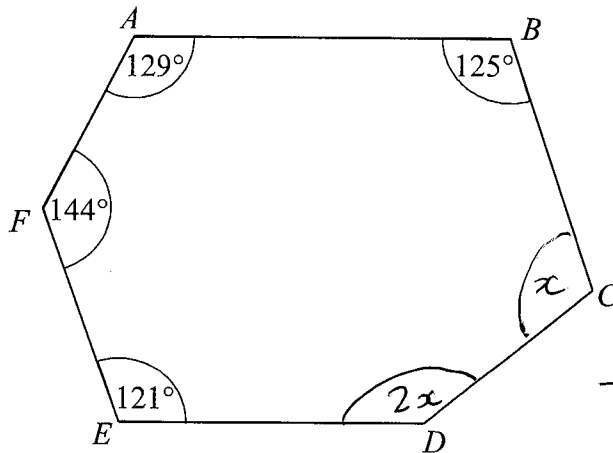

$$\begin{array}{r}
 129 \\
 125 \\
 144 \\
 + 121 \\
 \hline
 519
 \end{array}$$

$$720 - 519 = 201$$

ABCDEF is a hexagon.

Angle CDE = 2 × Angle BCD

Work out the size of angle CDE.

$$\begin{aligned}
 \text{Angles in a hexagon} &= (6 - 2) \times 180 \\
 &= 4 \times 180 \\
 &= \underline{\underline{720}}
 \end{aligned}$$

$$3 \overline{) 201}$$

$$x = 67$$

$$\begin{aligned}
 2x &= 2 \times 67 \\
 &= 134
 \end{aligned}$$

.....134.....°

(Total for question 8 is 3 marks)

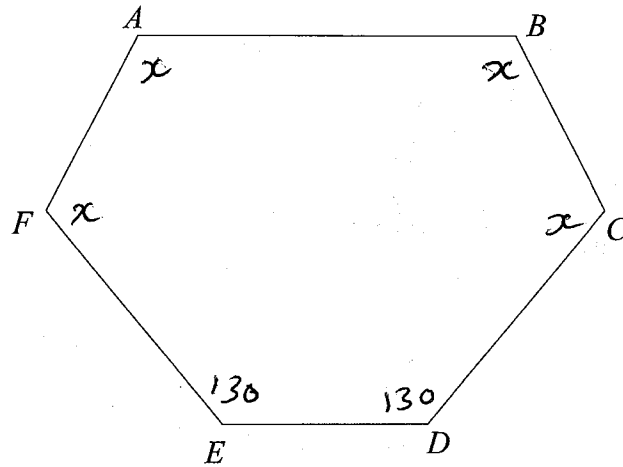

$ABCDEF$  is a hexagon.

Angle  $BAF =$  Angle  $ABC =$  Angle  $AFE =$  Angle  $BCD$ .  
 Angle  $DEF =$  Angle  $CDE = 130^\circ$

Work out the size of angle  $BAF$ .  
 You must show all your working.

$$\begin{aligned} \text{Angles in a hexagon} &= (6 - 2) \times 180 \\ &= 720^\circ \end{aligned}$$

$$\begin{aligned} 720 - 130 - 130 \\ 720 - 260 &= 460 \end{aligned}$$

$$\frac{460}{4} = \underline{115^\circ}$$

.....115..... $^\circ$

(Total for question 9 is 3 marks)

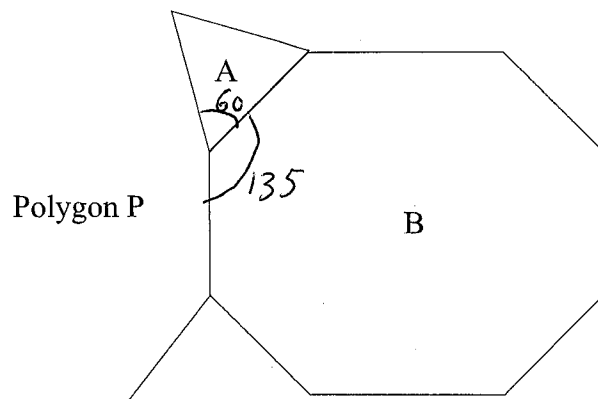

Shape A is a regular triangle. Shape B is a regular octagon.

Another regular polygon, P, is shown on the diagram.

How many sides does polygon P have?

You must show your working.

$$\text{Interior angle of } A = 60^\circ$$

$$\text{Exterior angle of } B = \frac{360}{8} = 45^\circ$$

$$\begin{aligned} \text{Interior angle of } B &= 180 - 45 \\ &= 135^\circ \end{aligned}$$

$$\begin{aligned} \text{Interior angle of } P &= 360 - 60 - 135 \\ &= 165^\circ \end{aligned}$$

$$\begin{aligned} \text{Exterior angle of } P &= 180 - 165 \\ &= 15^\circ \end{aligned}$$

$$\frac{360}{15} = \frac{120}{5} = 24$$

.....24.....

(Total for question 10 is 4 marks)

11

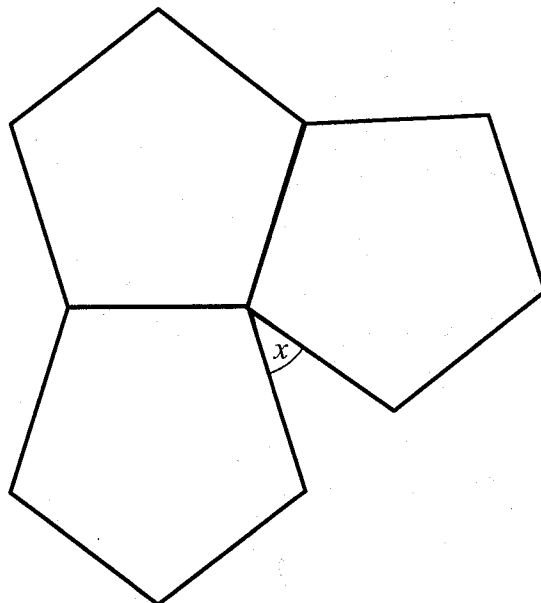

The diagram shows three regular pentagons meeting at a point.

Work out the size of the angle marked  $x$ .  
You must show all your working.

$$\text{Exterior angle of pentagon} = \frac{360}{5} = 72$$

$$\begin{aligned} \text{Interior angle of pentagon} &= 180 - 72 \\ &= 108^\circ \end{aligned}$$

$$3 \times 108 = 324$$

$$360 - 324 = \underline{\underline{36}}$$

..... 36 .....

(Total for question 11 is 3 marks)

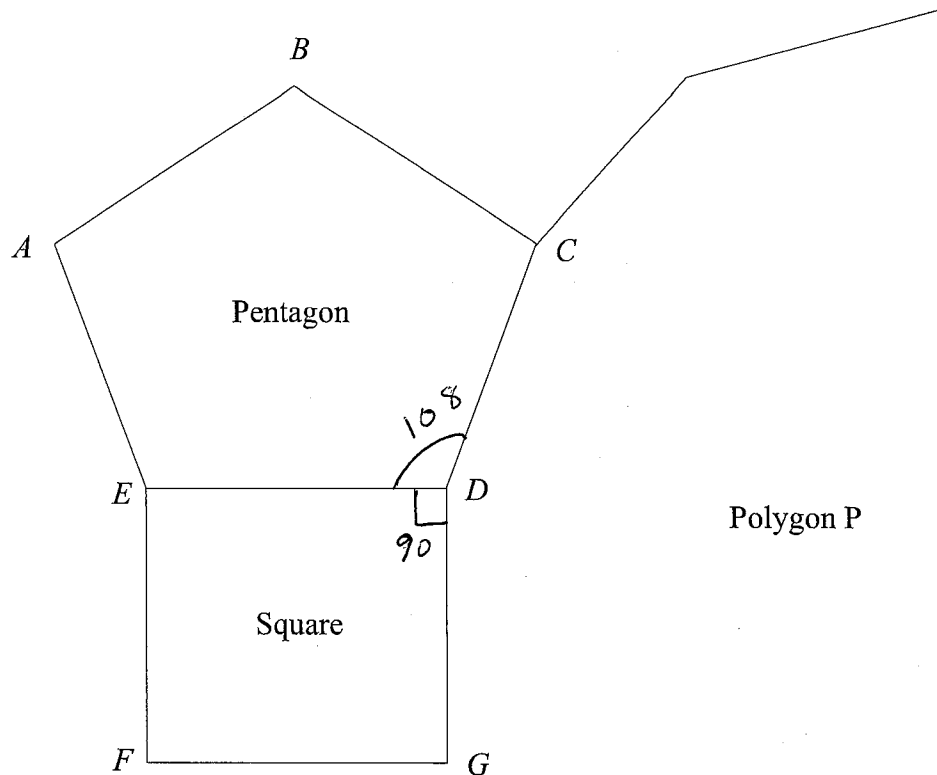

The diagram shows a regular pentagon, ABCDE, and a square, EDFG.

The lines CD and DG are both sides of another regular polygon, P.

How many sides does polygon P have?

You must show how you got your answer.

$$\text{Exterior angle of pentagon} = \frac{360}{5} = 72$$

$$\begin{aligned} \text{Interior angle of pentagon} &= \cancel{36} \\ &= 180 - 72 \\ &= 108 \end{aligned}$$

$$\begin{aligned} \text{Interior angle of } P &= 360 - 90 - 108 \\ &= 162^\circ \end{aligned}$$

$$\begin{aligned} \text{Exterior angle of } P &= 180 - 162 \\ &= 18 \end{aligned}$$

$$\frac{360}{18} = 20$$

..... 20

(Total for question 12 is 4 marks)

Name: \_\_\_\_\_

## GCSE (1 – 9)

# Angles in Parallel Lines

### Instructions

- Use **black** ink or ball-point pen.
- Answer all Questions.
- Answer the Questions in the spaces provided  
– *there may be more space than you need.*
- Diagrams are **NOT** accurately drawn, unless otherwise indicated.
- You must **show all your working out.**

### Information

- The marks for each Question are shown in brackets  
– *use this as a guide as to how much time to spend on each Question.*

### Advice

- Read each Question carefully before you start to answer it.
- Keep an eye on the time.
- Try to answer every Question.
- Check your answers if you have time at the end

1

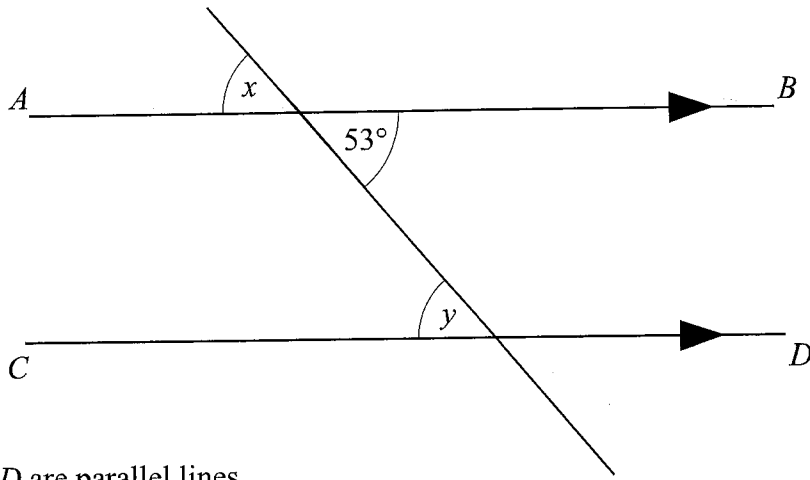

$AB$  and  $CD$  are parallel lines.

(a) Write down the size of angle  $x$ .

.....53.....<sup>o</sup>  
(1)

(b) Give a reason for your answer.

.....(vertically) opposite angles are equal.....  
.....  
(1)

(c) Write down the size of angle  $y$ .

.....53.....<sup>o</sup>  
(1)

(d) Give a reason for your answer.

.....alternate angles are equal.....  
.....  
(1)

(Total for question 1 is 4 marks)

2

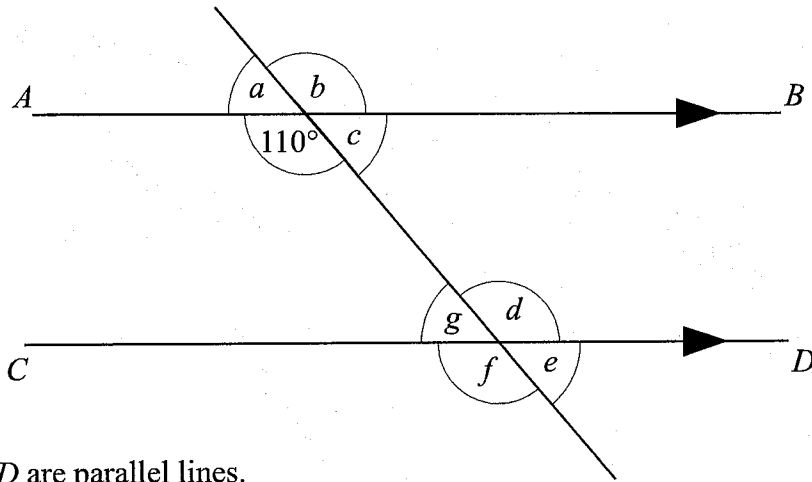

*AB* and *CD* are parallel lines.  
An angle of  $110^\circ$  is shown on the diagram.

(a) Write down the letter of one other angle of size  $110^\circ$

..... *f* .....  
(1)

(b) Give a reason for your answer.

..... *Corresponding angles are equal* .....

[ *or // b: opposite angles are equal d: alternate angles equal* ]  
(2)

(Total for question 2 is 3 marks)

3

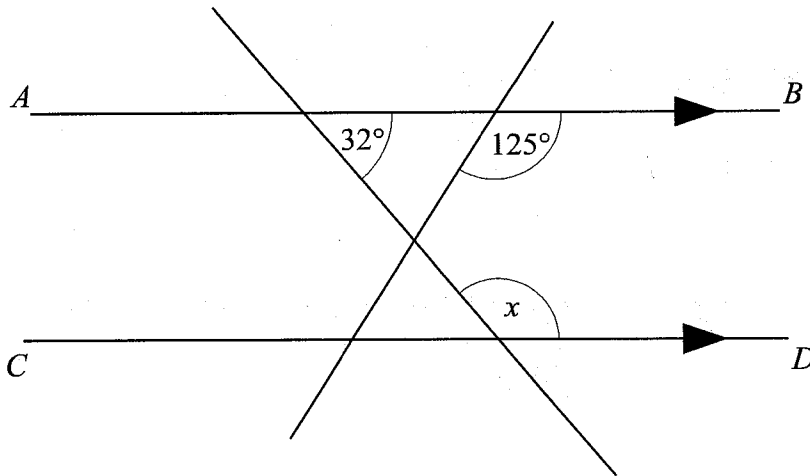

*AB* and *CD* are parallel lines.

(a) Find the size of angle *x*       $180 - 32 = 148$

..... *148°* .....  
(1)

(b) Give a reason for your answer.

..... *Co-interior angles add to  $180^\circ$*  .....

[ *or // angles on a straight line add to  $180^\circ$  AND* ]  
*Corresponding / alternate angles are equal* (2)

(Total for question 3 is 3 marks)

4

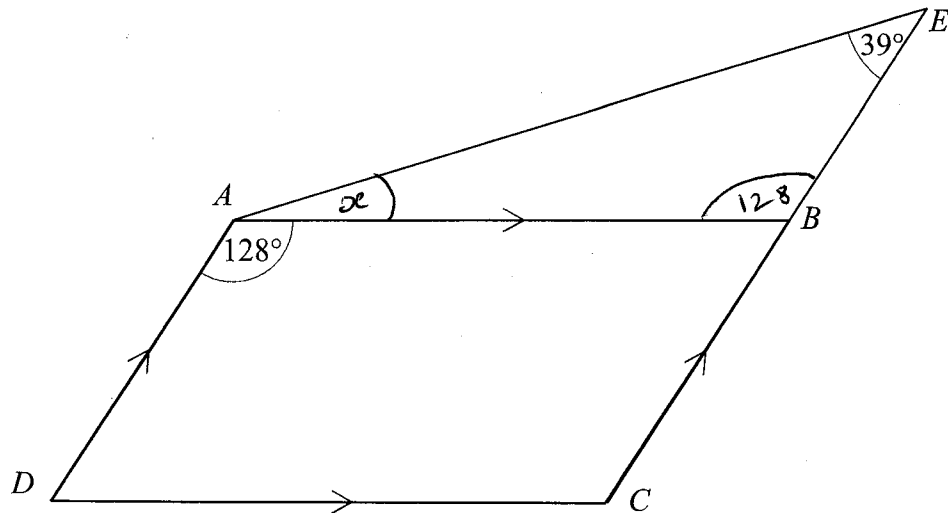

$ABCD$  is a parallelogram.

$CBE$  is a straight line.

Angle  $BAD = 128^\circ$

Angle  $AEB = 39^\circ$

Find the size of angle  $BAE$ .

Give a reason for each stage of your working.

Angle  $ABE = 128^\circ$       Alternate angles are equal

$$128 + 39 = 167^\circ$$

$$180 - 167 = 13^\circ$$

$BAE = 13^\circ$       Angles in a triangle add to  $180^\circ$

..... 13 .....

(Total for question 4 is 3 marks)

5

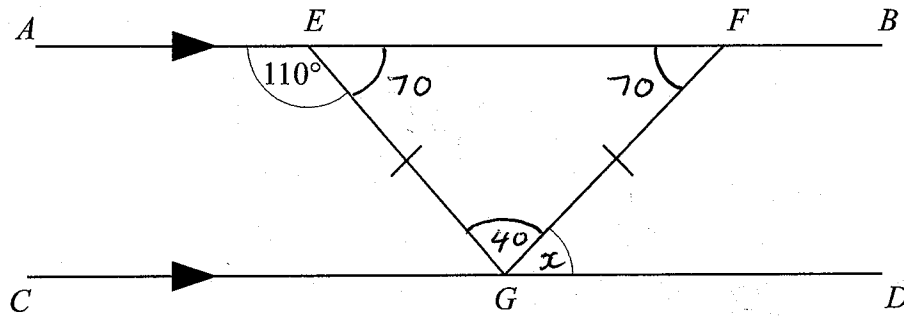

$AB$  and  $CD$  are parallel lines.  
 $EFG$  is an isosceles triangle

Angle  $AEG = 110^\circ$

Find the size of angle  $FGD$ .  
 Give a reason for each stage of your working.

$$\begin{aligned} \text{Angle } FEG &= 180 - 110 \\ &= 70^\circ \end{aligned}$$

Angle  $EFG = 70^\circ$       Angles at the base of  
 an isosceles triangle are  
 equal

~~$$\begin{aligned} \text{Angle } EGF &= 180 - 70 - 70 \\ &= 40 \end{aligned}$$

Angles in a triangle add to  $180^\circ$~~

$FGD = 70^\circ$       Alternate angles are equal

.....70..... $^\circ$

(Total for question 5 is 3 marks)

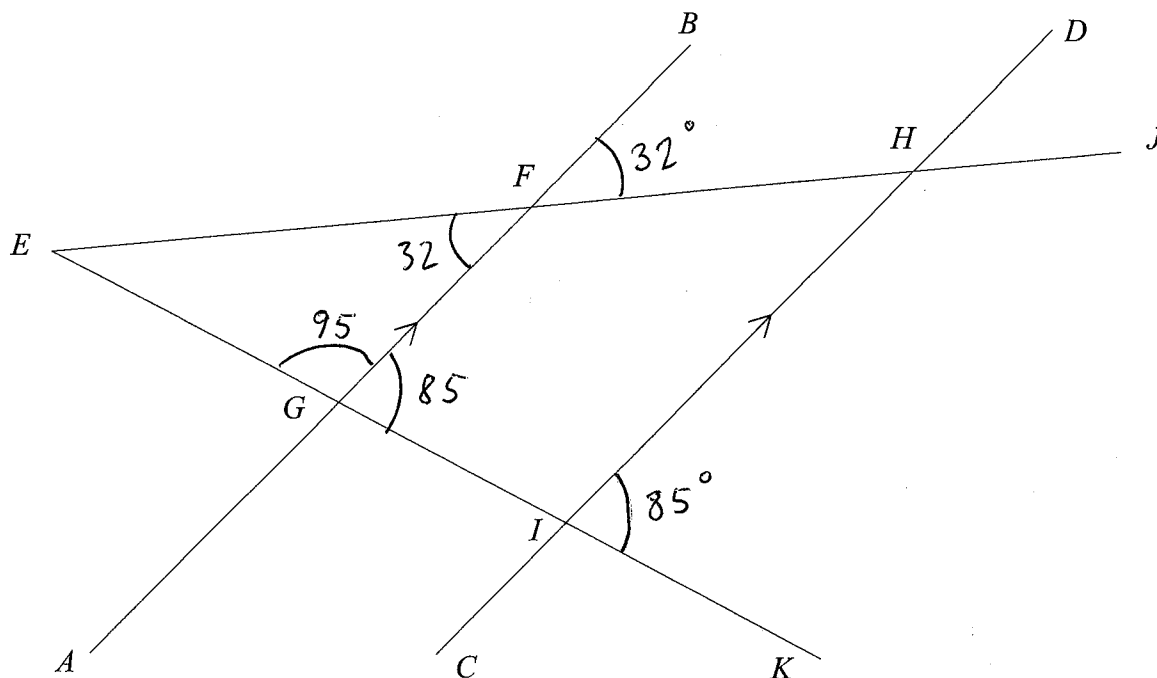

$AB$  and  $CD$  are parallel.

Angle  $HIK = 85^\circ$

Angle  $BFH = 32^\circ$

Find the size of angle  $FEG$ .

You must show how you got your answer.

$$EFH = 32^\circ \quad \text{opposite angles are equal}$$

$$FGI = 85^\circ \quad \text{corresponding angles are equal}$$

$$EGF = 95^\circ \quad \text{Angles on a straight line add to } 180^\circ$$

$$(180 - 85 = 95)$$

$$180 - 95 - 32 = 53^\circ$$

$$FEG = 53^\circ \quad \text{Angles in a triangle add to } 180^\circ$$

.....53.....°

(Total for question 6 is 3 marks)

7

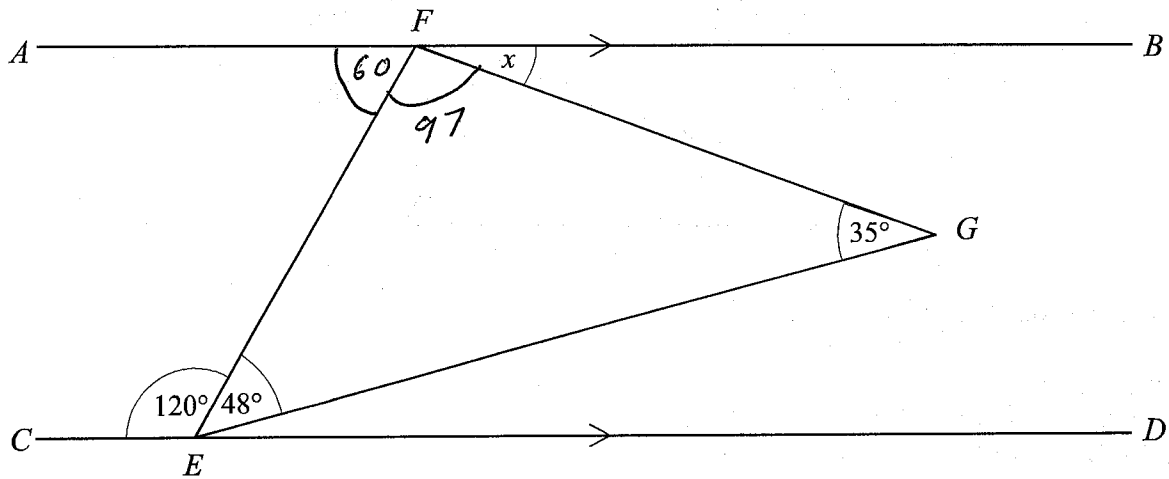

$AB$  and  $CD$  are parallel.

Find the size of angle  $x$ .

Give a reason for each stage of your working.

$$180 - 120 = 60$$

$$\angle AFE = 60^\circ \quad \text{Co interior angles add to } 180^\circ$$

$$\angle EFG = 180 - 48 - 35 = 97^\circ$$

Angles in a triangle add to  $180^\circ$

$$180 - 97 - 60 = 23^\circ$$

$$x = 23^\circ \quad \text{Angles on a straight line add to } 180^\circ$$

.....23.....°

(Total for question 7 is 4 marks)

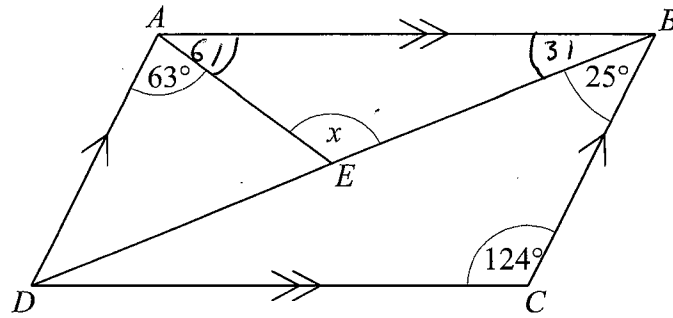

$ABCD$  is a parallelogram.

Angle  $DAE = 63^\circ$

Angle  $BCD = 124^\circ$

Angle  $CBD = 25^\circ$

Calculate the size of angle  $x$ .

Give reasons for each stage of your answer.

opposite angles in a parallelogram are equal

$$\therefore \angle BAD = 124^\circ$$

$$\angle BAE = 124 - 63 = 61^\circ$$

$$\angle ABC = 180 - 124 = 56^\circ$$

Co interior angles add to  $180^\circ$

$$\angle ABE = 56 - 25 = 31^\circ$$

$$180 - 61 - 31 = 88^\circ$$

Angles in a triangle add to  $180^\circ$

..... 88 .....

(Total for question 8 is 3 marks)

Name: \_\_\_\_\_

## GCSE (1 – 9)

### Pythagoras

#### Instructions

- Use **black** ink or ball-point pen.
- Answer all Questions.
- Answer the Questions in the spaces provided  
– *there may be more space than you need.*
- Diagrams are **NOT** accurately drawn, unless otherwise indicated.
- You must **show all your working out.**

#### Information

- The marks for each Question are shown in brackets  
– *use this as a guide as to how much time to spend on each Question.*

#### Advice

- Read each Question carefully before you start to answer it.
- Keep an eye on the time.
- Try to answer every Question.
- Check your answers if you have time at the end

1

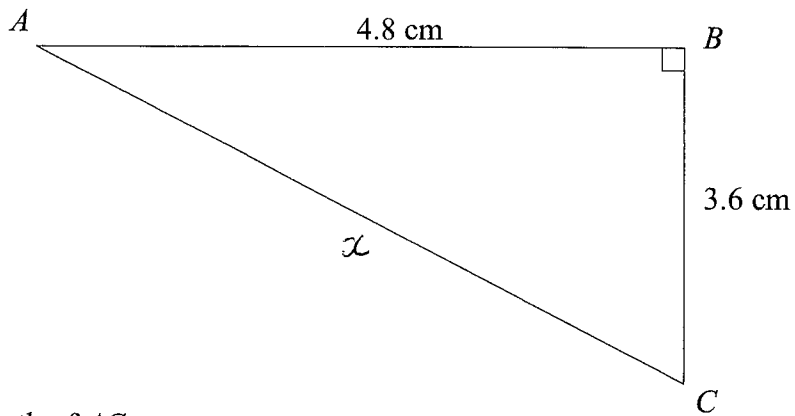

Calculate the length of AC.

$$3.6^2 + 4.8^2 = x^2$$

$$36 = x^2$$

$$x = \sqrt{36}$$

$$= 6$$

.....6.....cm

(Total for question 1 is 3 marks)

2

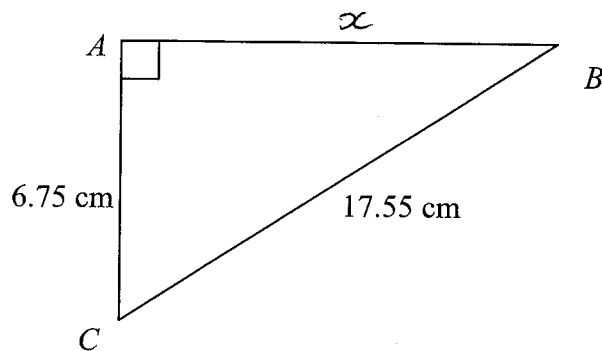

Calculate the length of ~~BC~~  
AB

$$x^2 + 6.75^2 = 17.55^2$$

$$x^2 = 17.55^2 - 6.75^2$$

$$x^2 = 262.44$$

$$x = \sqrt{262.44}$$

$$= 16.2$$

.....16.2.....cm

(Total for question 2 is 3 marks)

3

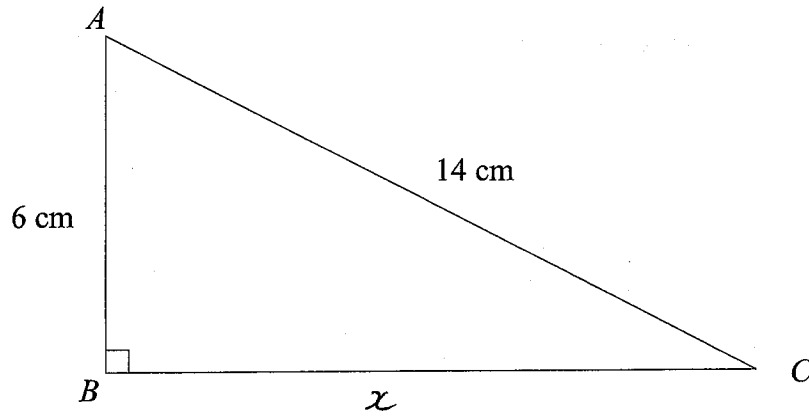

Calculate the length of BC.  
Give your answer to 1 decimal place.

$$x^2 + 6^2 = 14^2$$

$$x^2 = 14^2 - 6^2$$

$$x^2 = 160$$

$$x = \sqrt{160}$$

$$= 12.6 \text{ (1dp)}$$

.....12.6.....cm

(Total for question 3 is 3 marks)

4

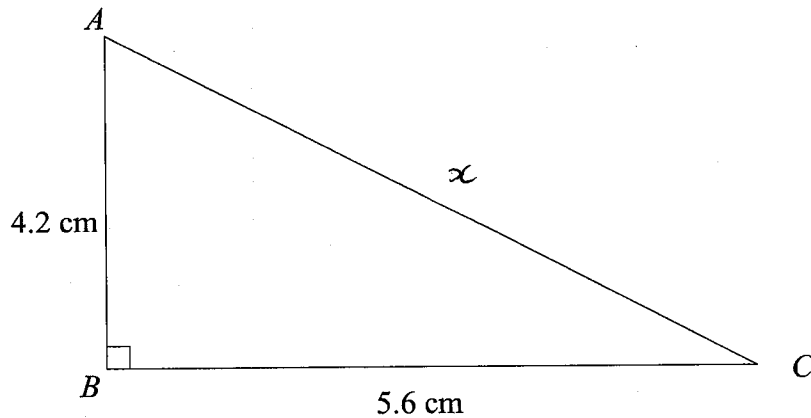

Calculate the length of AC.

$$4.2^2 + 5.6^2 = x^2$$

$$49 = x^2$$

$$x = \sqrt{49}$$

$$= 7$$

.....7.....cm

(Total for question 4 is 3 marks)

- 5 Calculate the length of the  $AD$ .  
Give your answer to 3 significant figures.

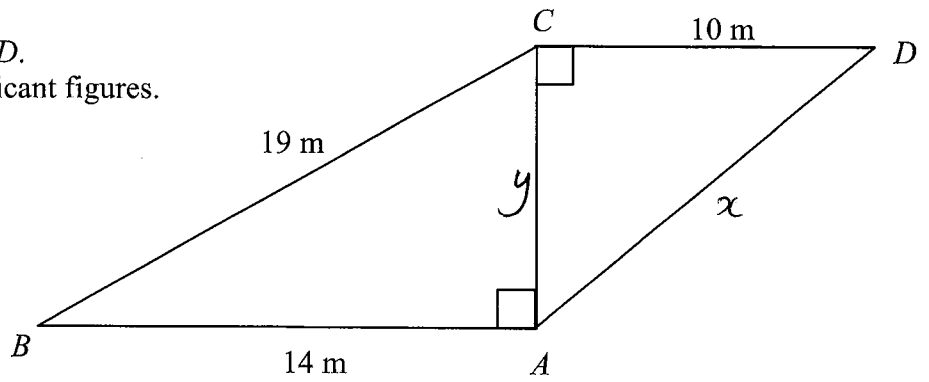

$$\begin{aligned}
 14^2 + y^2 &= 19^2 \\
 y^2 &= 19^2 - 14^2 \\
 y^2 &= 165 \\
 y &= \sqrt{165} \\
 &= 12.84523\dots
 \end{aligned}$$

$$\begin{aligned}
 10^2 + 12.84523^2 &= x^2 \\
 265 &= x^2 \\
 x &= \sqrt{265} \\
 &= \underline{\underline{16.3}} \text{ (3sf)}
 \end{aligned}$$

.....16.3.....m

(Total for question 5 is 4 marks)

- 6 Calculate the length of the  $AB$ .  
Give your answer to 3 significant figures.

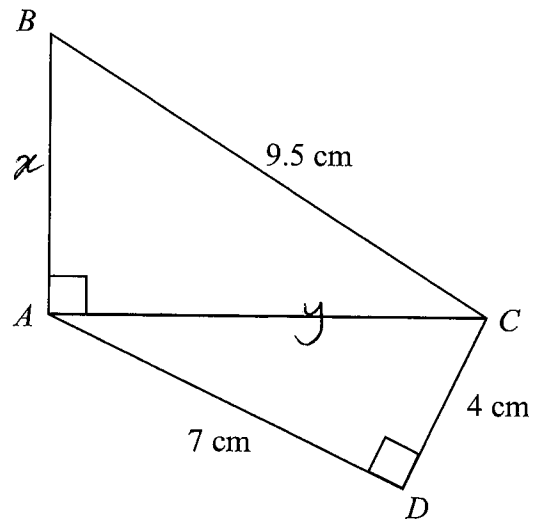

$$\begin{aligned}
 4^2 + 7^2 &= y^2 \\
 65 &= y^2
 \end{aligned}$$

$$x^2 + y^2 = 9.5^2$$

$$x^2 + 65 = 9.5^2$$

$$x^2 = 9.5^2 - 65$$

$$x^2 = 25.25$$

$$x = \sqrt{25.25}$$

$$= 5.02 \text{ (3sf)}$$

.....5.02.....cm

(Total for question 5 is 4 marks)

7

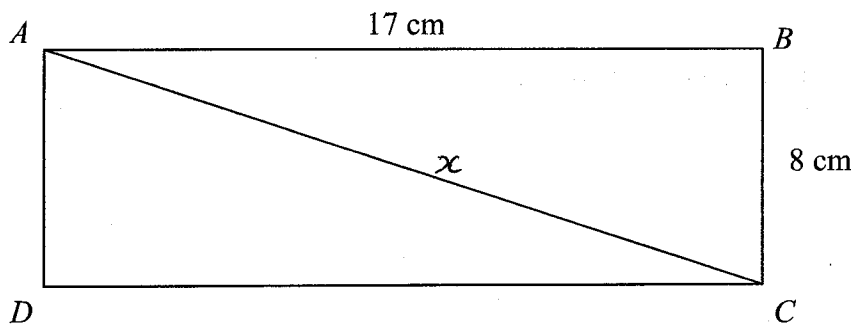

*ABCD* is a rectangle.

Calculate the length of the diagonal *AC*.

Give your answer correct to 1 decimal place.

$$8^2 + 17^2 = x^2$$

$$353 = x^2$$

$$x = \sqrt{353}$$

$$x = 18.8 \text{ (1dp)}$$

.....18.8.....cm

(Total for question 7 is 3 marks)

8

*ABCD* is a trapezium.

Calculate the length of *BC*.

$$x^2 + 15^2 = 17^2$$

$$x^2 = 17^2 - 15^2$$

$$x^2 = 64$$

$$x = \sqrt{64}$$

$$= 8$$

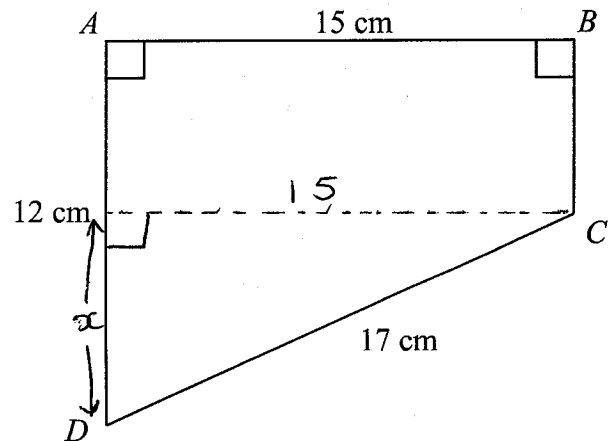

$$BC = 12 - 8 = 4$$

.....4.....cm

(Total for question 8 is 3 marks)

9  $ABC$  is an isosceles triangle.

Calculate the perpendicular height of  $ABC$ .  
Give your answer correct to 3 significant figures..

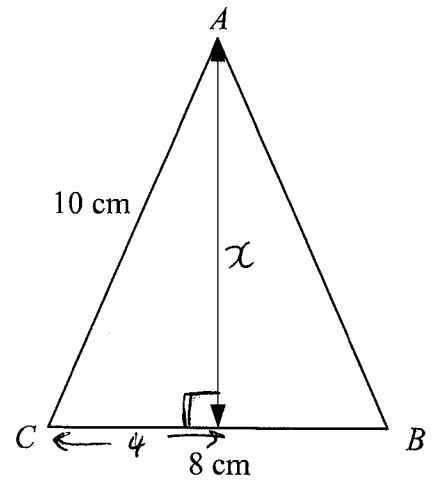

$$\begin{aligned} x^2 + 4^2 &= 10^2 \\ x^2 &= 10^2 - 4^2 \\ x^2 &= 84 \\ x &= \sqrt{84} \\ &= 9.17 \text{ (3sf)} \end{aligned}$$

.....9.17.....cm

(Total for question 9 is 3 marks)

10  $ABCD$  is a trapezium.

Calculate the length of  $AC$ .  
Give your answer correct to 3 significant figures..

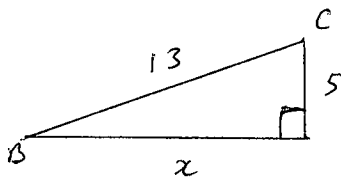
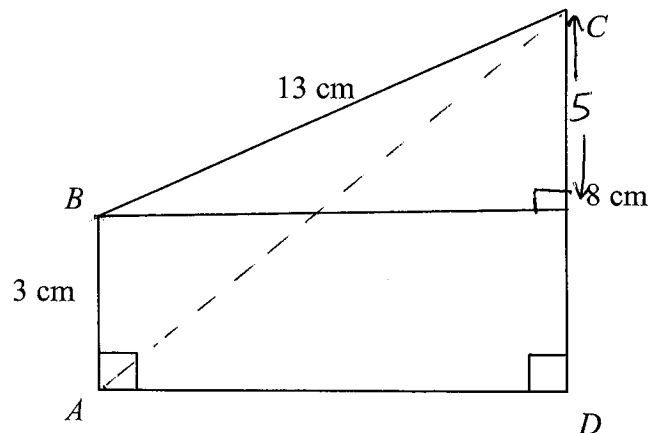

$$\begin{aligned} x^2 + 5^2 &= 13^2 \\ x^2 &= 13^2 - 5^2 \\ x^2 &= 144 \\ x &= \sqrt{144} \\ &= 12 \end{aligned}$$

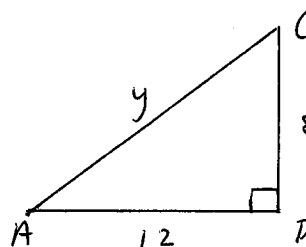

$$\begin{aligned} 8^2 + 12^2 &= y^2 \\ y^2 &= 208 \\ y &= \sqrt{208} \\ y &= 14.4 \\ &\text{(3sf)} \end{aligned}$$

.....14.4.....cm

(Total for question 10 is 4 marks)

- 11 A ship leaves point A and sails for 3.7 km due North.  
The ship then sails for 2.4 km due East to reach point B.

Calculate the the shortest distance between point A and point B.  
Give your answer correct to 1 decimal place.

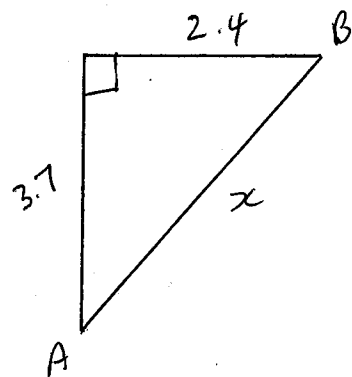

$$2.4^2 + 3.7^2 = x^2$$

$$x^2 = 19.45$$

$$x = \sqrt{19.45}$$

$$= 4.4 \text{ km (1dp)}$$

..... 4.4 ..... km

(Total for question 11 is 3 marks)

- 12 A ladder reaches <sup>250cm</sup> 2.5 m up a vertical wall.  
The base of the ladder is 70 cm from the base of the wall on a horizontal ground.

Find the length of the ladder.

$$70^2 + 250^2 = x^2$$

$$67400 = x^2$$

$$x^2 = 67400$$

$$x = \sqrt{67400}$$

$$= 259.6150997 \text{ cm}$$

$$= 260 \text{ cm (nearest cm)}$$

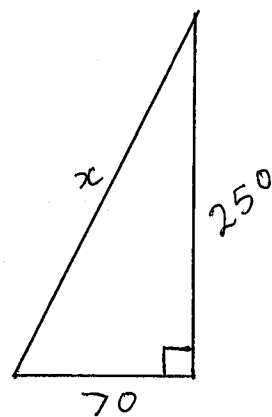

..... 260 cm .....

(Total for question 12 is 4 marks)

OR 2.6 m

- 13  $ABCD$  is a square.  
The diagonal of the square is 8 m.

Calculate the perimeter of the square.  
Give your answer correct to one decimal place.

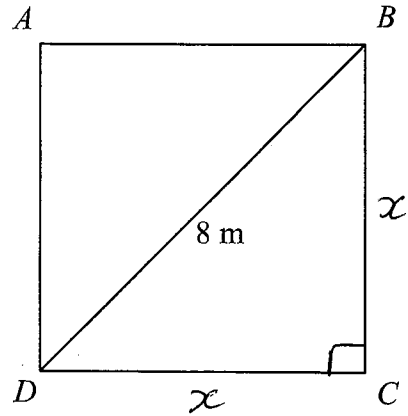

$$x^2 + x^2 = 8^2$$

$$2x^2 = 64$$

$$x^2 = 32$$

$$x = \sqrt{32}$$

$$= 5.656854249 \text{ m}$$

$$4 \times 5.656\dots = 22.6 \text{ m (1dp)}$$

.....22.6.....m

(Total for question 13 is 3 marks)

- 14 A television has a diagonal length of 50 inches.

The ratio of the length of the television to the width of the television is 4:3

Calculate the length and the width of the television.  
Give your answers correct to 1 decimal place.

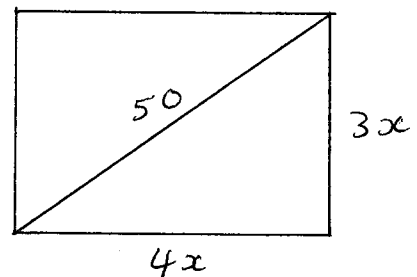

$$(3x)^2 + (4x)^2 = 50^2$$

$$9x^2 + 16x^2 = 2500$$

$$25x^2 = 2500$$

$$x^2 = 100$$

$$x = 10$$

$$4 \times 10 = 40$$

$$3 \times 10 = 30$$

Length .....40..... inches

Width .....30..... inches

(Total for question 14 is 3 marks)

Name: \_\_\_\_\_

## GCSE (1 – 9)

# Expanding and Factorising

### Instructions

- Use **black** ink or ball-point pen.
- Answer all Questions.
- Answer the Questions in the spaces provided  
– *there may be more space than you need.*
- Diagrams are **NOT** accurately drawn, unless otherwise indicated.
- You must **show all your working out.**

### Information

- The marks for each Question are shown in brackets  
– *use this as a guide as to how much time to spend on each Question.*

### Advice

- Read each Question carefully before you start to answer it.
- Keep an eye on the time.
- Try to answer every Question.
- Check your answers if you have time at the end

1 (a) Expand  $7(2x + 7)$

$$\frac{14x + 49}{(1)}$$

(b) Factorise  $3y + 12$

$$\frac{3(y + 4)}{(1)}$$

(Total for Question 1 is 2 marks)

2 (a) Expand  $5a(a - 6)$

$$\frac{5a^2 - 30a}{(2)}$$

(b) Solve  $4(b + 2) = 24$

$$4b + 8 = 24$$

$$4b = 16$$

$$b = 4$$

$$b = \frac{4}{(2)}$$

(Total for Question 2 is 4 marks)

3 (a) Factorise fully  $12m + 8m^2$

$$\frac{4m(3 + 2m)}{(2)}$$

(b) Solve  $3(n - 5) = 27$

$$3n - 15 = 27$$

$$3n = 42$$

$$n = 14$$

$$n = \frac{14}{(2)}$$

(Total for Question 3 is 4 marks)

4 (a) Expand  $8(3s - 2)$

$$\underline{24s - 16}$$

(1)

(b) Factorise  $4t + 20$

$$\underline{4(t + 5)}$$

(1)

(Total for Question 4 is 2 marks)

5 (a) Factorise fully  $5a^2b + 15ab^2$

$$\underline{5ab(a + 3b)}$$

(2)

(b) Solve  $6(c - 8) = 42$

$$6c - 48 = 42$$

$$6c = 90$$

$$c = 15$$

$$c = \underline{15}$$

(2)

(Total for Question 5 is 4 marks)

6 (a) Factorise  $18x + 24$

$$\underline{6(3x + 4)}$$

(1)

(b) Expand  $3(2y - 4)$

$$\underline{6y - 12}$$

(1)

(Total for Question 6 is 2 marks)

7 (a) Expand  $p(p-3)$

$$\frac{p^2 - 3p}{(1)}$$

(b) Factorise  $16q + 8$

$$\frac{8(2q + 1)}{(1)}$$

(Total for Question 7 is 2 marks)

8 (a) Factorise fully  $6x^2 - 4xy$

$$\frac{2x(3x - 2y)}{(2)}$$

(b) Solve  $2(w-4) = 13$

$$2w - 8 = 13$$

$$2w = 21$$

$$w = \frac{21}{2}$$

$$w = \frac{21}{2} \text{ or } 10.5$$

(2)

(Total for Question 8 is 4 marks)

9 (a) Factorise  $x^2 - 9x$

$$\frac{x(x - 9)}{(1)}$$

(b) Expand  $6(5y + 1)$

$$\frac{30y + 6}{(1)}$$

(Total for Question 9 is 2 marks)

10 (a) Expand  $3(5x - 8)$

$$\frac{15x - 24}{(1)}$$

(b) Factorise  $18y + 15$

$$\frac{3(6y + 5)}{(1)}$$

(Total for Question 10 is 2 marks)

11 (a) Expand  $7(2h - 3)$

$$\frac{14h - 21}{(1)}$$

(b) Expand and Simplify  $4(g + 5) + 3(g - 2)$

$$4g + 20 + 3g - 6$$

$$\frac{7g + 14}{(2)}$$

(Total for Question 11 is 3 marks)

12 (a) Factorise fully  $7xy + 21x$

$$\frac{7x(y + 3)}{(2)}$$

(b) Solve  $6(p + 3) = 42$

$$6p + 18 = 42$$

$$6p = 24$$

$$p = 4$$

$$p = \frac{4}{(2)}$$

(Total for Question 12 is 4 marks)

13 (a) Expand  $a(a + b)$

$$\frac{a^2 + ab}{(1)}$$

(b) Factorise  $15y - 6$

$$\frac{3(5y - 2)}{(1)}$$

(Total for Question 13 is 2 marks)

14 (a) Expand  $9x(3y - 8)$

$$\frac{27xy - 72x}{(2)}$$

(b) Expand and Simplify  $7(t - 4) + 5(t - 2)$

$$\cancel{7t - 28 + 5t - 10}$$

$$7t - 28 + 5t - 10$$

$$\frac{12t - 38}{(2)}$$

(Total for Question 14 is 4 marks)

15 (a) Factorise fully  $30x^3 + 12x$

$$\frac{6x(5x^2 + 2)}{(2)}$$

(b) Solve  $5(f - 2) = 22$

$$5f - 10 = 22$$

$$5f = 32$$

$$f = \frac{32}{5}$$

$$f = \frac{32}{5} \text{ or } 6.4$$

(Total for Question 15 is 4 marks)

16 (a) Expand  $x(8x + 1)$

$$\frac{8x^2 + x}{(1)}$$

(b) Factorise  $18 + 63y$

$$\frac{9(2 + 7y)}{(1)}$$

(Total for Question 16 is 2 marks)

17 (a) Expand  $2x^2(4x - 9)$

$$\frac{8x^3 - 18x^2}{(2)}$$

(b) Expand and Simplify  $6(y + 3) - 5(y - 4)$

$$6y + 18 - 5y + 20$$

$$\frac{y + 38}{(2)}$$

(Total for Question 17 is 4 marks)

18 (a) Factorise fully  $30a^2 + 40ab$

$$\frac{10a(3a + 4b)}{(2)}$$

(b) Solve  $3(g + 9) = 21$

$$3g + 27 = 21$$

$$3g = -6$$

$$g = -2$$

$$g = \frac{-2}{(2)}$$

(Total for Question 18 is 4 marks)

19 (a) Expand  $n(5n + 1)$

$$\frac{5n^2 + n}{(1)}$$

(b) Factorise  $18m + mn$

$$\frac{m(18 + n)}{(1)}$$

(Total for Question 19 is 2 marks)

20 (a) Expand  $3x(7x^2 - y)$

$$\frac{21x^3 - 3xy}{(2)}$$

(b) Expand and Simplify  $3(6y + 5) - 2(4y - 1)$

$$18y + 15 - 8y + 2$$

$$\frac{10y + 17}{(2)}$$

(Total for Question 20 is 4 marks)

21 (a) Factorise fully  $18a^2bc + 30abc^2$

$$\frac{6abc(3a + 5c)}{(2)}$$

(b) Expand and Simplify  $4(2y - 7) - 3(5y - 3)$

$$8y - 28 - 15y + 9$$

$$\frac{-7y - 19}{(2)}$$

(Total for Question 21 is 4 marks)

Name: \_\_\_\_\_

# GCSE (1 – 9)

## Sequences

### Instructions

- Use **black** ink or ball-point pen.
- Answer all Questions.
- Answer the Questions in the spaces provided  
– *there may be more space than you need.*
- Diagrams are **NOT** accurately drawn, unless otherwise indicated.
- You must **show all your working out.**

### Information

- The marks for each Question are shown in brackets  
– *use this as a guide as to how much time to spend on each Question.*

### Advice

- Read each Question carefully before you start to answer it.
- Keep an eye on the time.
- Try to answer every Question.
- Check your answers if you have time at the end

1 Here are the first five terms of a sequence.

2                    4                    7                    11                    16  
                  +2                    +3                    +4                    +5

Write down the next two terms in the sequence.

$$16 + 6 = 22$$

$$22 + 7 = 29$$

..... 22 , ..... 29  
(Total for Question 1 is 2 marks)

2 The first term in a sequence is 3.  
The term to term rule is add 5.

3                    8                    13                    18                    23                    ...

Is 97 a term in the sequence?  
Give a reason for your answer.

No, all terms in the sequence end  
in 3 or 8

(Total for Question 2 is 2 mark)

3 Here are the first five terms of a Fibonacci sequence

1                    2                    3                    5                    8

Write down the next two terms in the sequence.

$$5 + 8 = 13$$

$$8 + 13 = 21$$

..... 13 , ..... 21  
(Total for Question 3 is 2 marks)

4 The nth term of a sequence is  $4n + 3$

(a) Find the first two terms of this sequence.

$$4(1) + 3 = 7$$

$$4(2) + 3 = 11$$

..... 7 , ..... 11

(b) Is 35 a term in this sequence.  
You must show how you get your answer.

$$4n + 3 = 35$$

$$4n = 32$$

$$n = 8$$

Yes, 35 is the 8<sup>th</sup> term in the  
sequence

(Total for Question 4 is 2 marks)

5 The  $n$ th term of a sequence is  $n^2 + 1$

$$(1)^2 + 1 = 2$$

(a) Find the first two terms of this sequence.

$$(2)^2 + 1 = 5$$

..... 2 , ..... 5  
(1)

(b) Is 35 a term in this sequence.  
You must show how you get your answer.

$$n^2 + 1 = 35$$

$$n^2 = 34$$

$$n = \sqrt{34} \text{ [not a whole no.]}$$

..... No, 35 is not one more than a square  
..... number  
(1)

(Total for Question 5 is 2 marks)

6 Here are the first 5 terms of a sequence.

17

14

11

8

5

(a) Find the next term of this sequence.

..... 2  
(1)

The  $n$ th term of a different sequence is  $10n^2 + 5$

(b) Work out the 5<sup>th</sup> term of this sequence.

$$10(5)^2 + 5$$

$$10(25) + 5$$

$$250 + 5$$

..... 255  
(1)

(Total for Question 6 is 2 marks)

7 Here are the first four terms of a sequence.

7

13

19

25

(a) Write down the next term in the sequence.

..... 31  
(1)

(b) Explain how you got your answer

..... added 6 onto the previous term  
(1)

(Total for Question 7 is 2 marks)

8 Here are the first four terms of a number sequence.

2                      3                      5                      9

The rule to continue the sequence is  
multiply the previous term by 2 and then subtract 1

Work out the 5<sup>th</sup> term of this sequence.

$$9 \times 2 = 18$$
$$18 - 1 = 17$$

.....  
17

(Total for Question 8 is 1 mark)

9 Here are the first 5 terms of a Fibonacci sequence.

2                      2                      4                      6                      10

Find the 8th term of this sequence.

$$6 + 10 = 16$$
$$10 + 16 = 26$$
$$16 + 26 = 42$$

.....  
42

(Total for Question 9 is 2 marks)

10 The  $n$ th term of a sequence is  $n^2 + 3$

(a) Find the first three terms of this sequence.

$$(1)^2 + 3 = 4$$
$$(2)^2 + 3 = 7$$
$$(3)^2 + 3 = 12$$

.....  
4 , 7 , 12  
(2)

(b) Find the 10<sup>th</sup> term in this sequence.

$$(10)^2 + 3$$
$$100 + 3$$

.....  
103

(1)

(Total for Question 10 is 3 marks)

11 Here is a sequence of patterns made from white tiles and grey tiles.

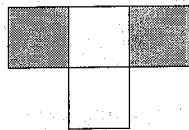

pattern number 1

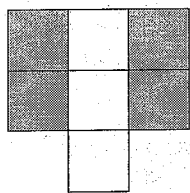

pattern number 2

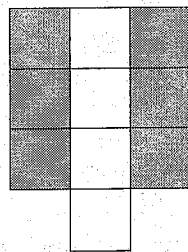

pattern number 3

(a) In the space below, draw pattern number 4.

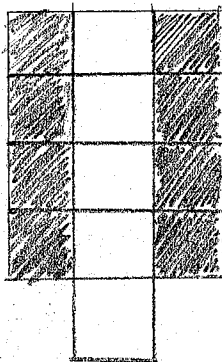

(1)

(b) Work out the total number of tiles to make pattern number 7.

4    7    10    13    16    19    22

..... 22 .....  
(2)

Kyle says

“There are 4 white tiles in pattern number 3 so there will be 8 white tiles in pattern number 6.”

(c) Is Kyle right?

You must give a reason for your answer.

No. There will be 7 white tiles in pattern 6.

(1)

(Total for Question 11 is 4 marks)

12 Here is a sequence of patterns made from grey counters.

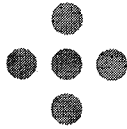

pattern number 1

5

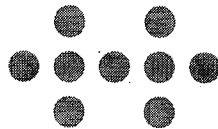

pattern number 2

9

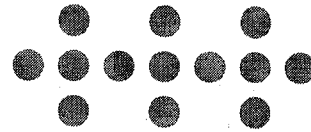

pattern number 3

13

(a) In the space below, draw pattern number 4.

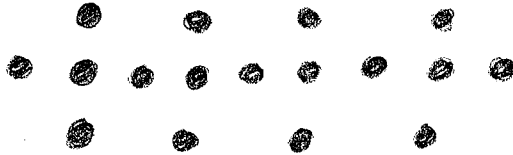

(b) Work out the total number of counters to make pattern number 10. (1)

|      |   |   |    |    |
|------|---|---|----|----|
|      | 5 | 9 | 13 | 17 |
| $4n$ | 4 | 8 | 12 | 16 |

$$4n + 1$$

$$4(10) + 1 = 41$$

41

(2)

(Total for Question 12 is 3 marks)

13 Here are the first five terms of a sequence.

31                  27                  23                  19                  15

(a) Find the first negative term in the sequence.

11                  7                  3                  -1

-1

(b) Is -30 a term in this sequence?  
Give a reason for your answer.

(2)

No. All terms in the sequence are odd

(1)

(Total for Question 13 is 3 marks)

14 Here are the first 5 terms of an arithmetic sequence.

-3                      1                      5                      9                      13

(a) Find an expression, in terms of  $n$ , for the  $n$ th term of this sequence.

$4n$     4                      8                      12                      16                      20

$$\underline{4n - 7}$$

(2)

The  $n$ th term of a different arithmetic sequence is  $2n - 3$

(b) Is 101 a term in this sequence?  
Show how you get your answer.

$$\begin{aligned} 2n - 3 &= 101 \\ 2n &= 104 \\ n &= 52 \end{aligned}$$

(2)

Yes, it is the 52nd term.

(Total for Question 14 is 4 marks)

15 Here are the first 5 terms of a sequence.

9                      14                      19                      24                      29

Find an expression, in terms of  $n$ , for the  $n$ th term of this sequence.

$5n$     5                      10                      15                      20                      25

$$\underline{5n + 4}$$

(Total for Question 15 is 2 marks)

16 Here are the first 5 terms of a sequence.

25                      22                      19                      16                      13

Find an expression, in terms of  $n$ , for the  $n$ th term of this sequence.

$-3n$     -3                      -6                      -9                      -12                      -15

$$\underline{-3n + 28}$$

(Total for Question 16 is 2 marks)

17 Here are the first four terms of an arithmetic sequence.

4                      11                      18                      25

Write down an expression, in terms of  $n$ , for the  $n$ th term of the sequence.

$7n$     7            14            21            28

$7n - 3$

(Total for Question 17 is 2 marks)

18 Here are the first four terms of an arithmetic sequence.

35                      31                      27                      23

Write down an expression, in terms of  $n$ , for the  $n$ th term of the sequence.

$-4n$     -4            -8            -12            -16

$-4n + 39$

(Total for Question 18 is 2 marks)

19 Here are the first five terms of an arithmetic sequence.

21                      27                      33                      39                      45

Write down an expression, in terms of  $n$ , for the  $n$ th term of the sequence.

$6n$     6            12            18            24            30

$6n + 15$

(Total for Question 19 is 2 marks)

20 Here are the first five terms of an arithmetic sequence.

2                      7                      12                      17                      22

Write down an expression, in terms of  $n$ , for the  $n$ th term of the sequence.

$5n$     5            10            15            20            25

$5n - 3$

(Total for Question 20 is 2 marks)

Name: \_\_\_\_\_

## GCSE (1 – 9)

# Forming and Solving Equations

### Instructions

- Use **black** ink or ball-point pen.
- Answer all questions.
- Answer the questions in the spaces provided  
– *there may be more space than you need.*
- Diagrams are **NOT** accurately drawn, unless otherwise indicated.
- You must **show all your working out.**

### Information

- The marks for each question are shown in brackets  
– *use this as a guide as to how much time to spend on each question.*

### Advice

- Read each question carefully before you start to answer it.
- Keep an eye on the time.
- Try to answer every question.
- Check your answers if you have time at the end

- 1 The lengths, in cm, of the sides of a triangle are  $3x - 5$ ,  $2x - 1$  and  $x + 1$

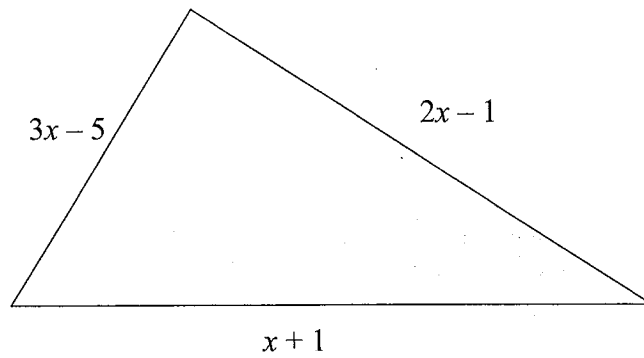

- (a) Write down an expression, in terms of  $x$ , for the perimeter of the triangle.

$$3x - 5 + 2x - 1 + x + 1$$

$$\underline{6x - 5} \text{ cm}$$

(2)

The perimeter of the triangle is 31 cm.

- (b) Work out the value of  $x$ .

$$6x - 5 = 31$$

$$6x = 36$$

$$x = 6$$

$$\underline{6} \text{ [cm]}$$

(2)

**(Total for question 1 is 4 marks)**

- 2 A rectangle has a length of  $(2x + 3)$  cm and a width of  $(x + 5)$  cm.

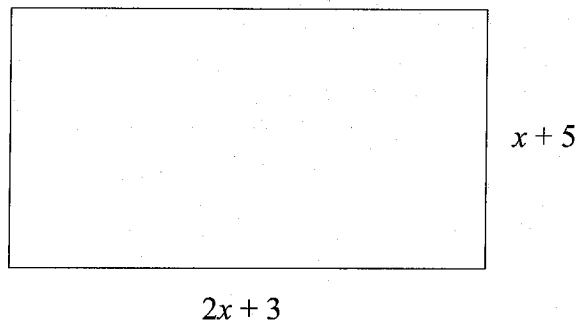

- (a) Find an expression for the perimeter of the rectangle.

$$2(2x + 3) + 2(x + 5)$$

$$4x + 6 + 2x + 10$$

$$6x + 16$$

$$\underline{6x + 16} \text{ cm}$$

(2)

- (b) Given the rectangle has a perimeter of 43 cm find the value of  $x$ .

$$6x + 16 = 43$$

$$6x = 27$$

$$x = \frac{27}{6} = \frac{9}{2} = 4.5$$

$$\underline{4.5 \text{ [cm]}}$$

(2)

(Total for question 2 is 4 marks)

$$\left( \text{or } \frac{9}{2} \right)$$

3

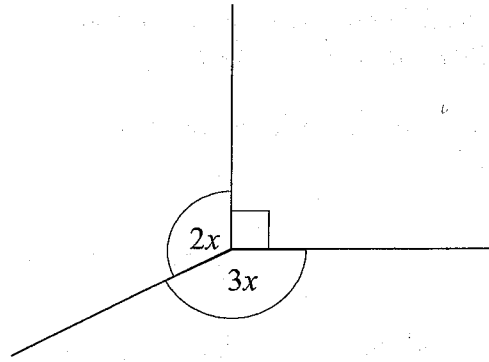
Find the value of  $x$ .

$$2x + 3x + 90 = 360$$

$$5x + 90 = 360$$

$$5x = 270$$

$$x = 54$$

54°

(Total for question 3 is 3 marks)

4 The diagram shows a right angled triangle.

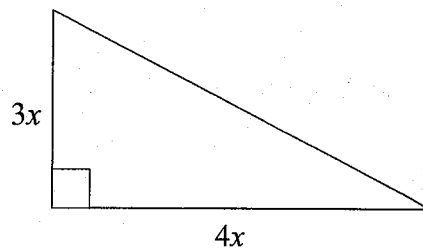
The area of the triangle is  $294 \text{ cm}^2$ Work out the value of  $x$ .

$$\frac{1}{2} \times 4x \times 3x = 294$$

$$\frac{1}{2} \times 12x^2 = 294$$

$$6x^2 = 294$$

$$x^2 = \frac{294}{6} = \frac{147}{3} = 49$$

$$x = \sqrt{49}$$

$$= 7$$

7 [cm]

(Total for question 4 is 3 marks)

- 5 The sizes of the angles, in degrees, of a triangle are  $2x + 9$ ,  $x + 13$  and  $x - 8$

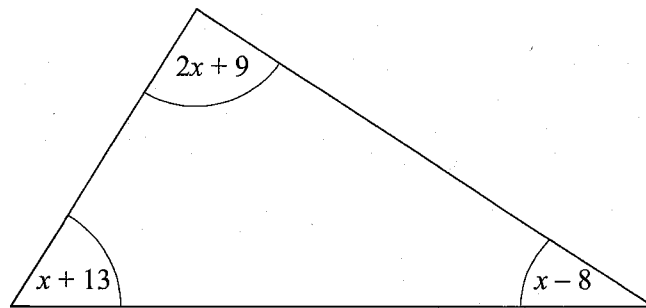

Work out the value of  $x$ .

$$2x + 9 + x - 8 + x + 13 = 180$$

$$4x + 14 = 180$$

$$4x = 166$$

$$x = \frac{166}{4} = \frac{83}{2} = 41.5$$

$$\underline{41.5 \text{ or } \frac{83}{2}}$$

(Total for question 5 is 3 marks)

- 6 The diagram shows a rectangle.  
All measurements are in centimetres.

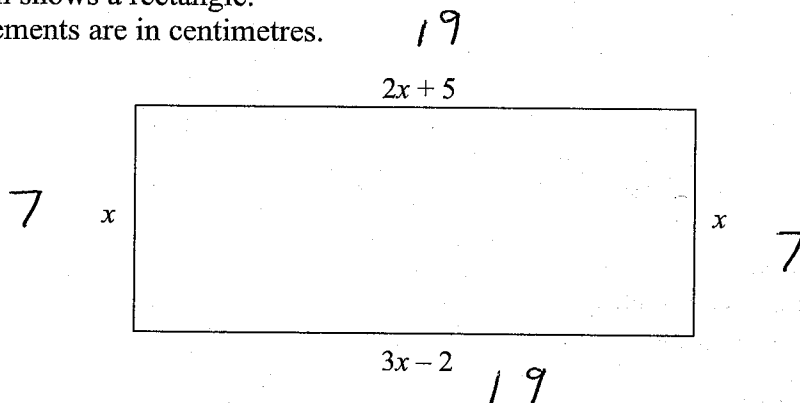

Find the perimeter of the rectangle.

$$2x + 5 = 3x - 2$$

$$5 = x - 2$$

$$\underline{7 = x}$$

$$2(7) + 5 = 19$$

$$2(19) + 2(7)$$

$$38 + 14$$

$$\underline{52}$$

cm

(Total for question 6 is 3 marks)

- 7 The diagram shows a rectangle and a triangle.

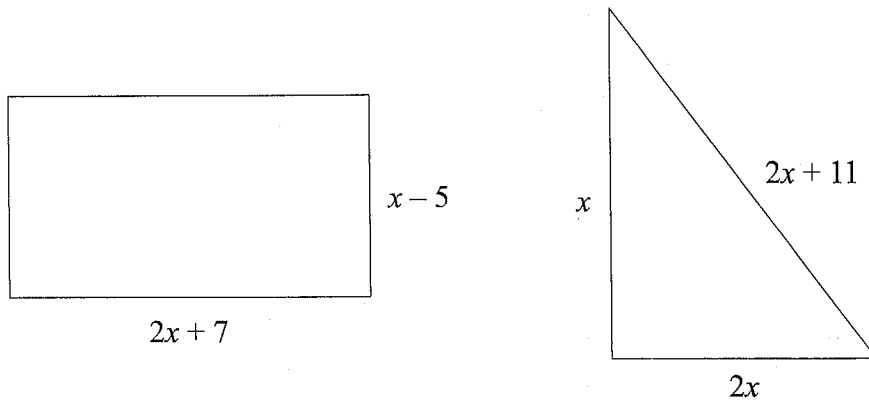

The perimeter of the rectangle is equal to the perimeter of the triangle.

Find the value of  $x$ .

$$\begin{aligned}
 2(x-5) + 2(2x+7) &= x + 2x + 2x + 11 \\
 2x - 10 + 4x + 14 &= 5x + 11 \\
 6x + 4 &= 5x + 11 \\
 x + 4 &= 11 \\
 x &= 7
 \end{aligned}$$

(Total for question 7 is 3 marks)

8

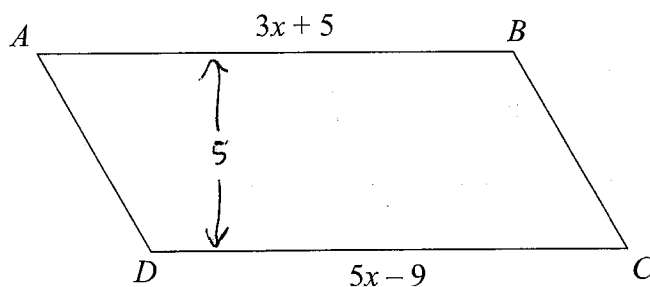

$ABCD$  is a parallelogram

All measurements are in centimetres.

The perpendicular height of the parallelogram is 5 cm.

Find the area of  $ABCD$

$$\begin{aligned}
 3x + 5 &= 5x - 9 \\
 5 &= 2x - 9 \\
 14 &= 2x \\
 x &= 7
 \end{aligned}$$

$$3(7) + 5 = 26$$

$$26 \times 5$$

$$130 \text{ cm}^2$$

(Total for question 8 is 4 marks)

- 9 The diagram shows a right-angled triangle.  
All of the angles are in degrees.

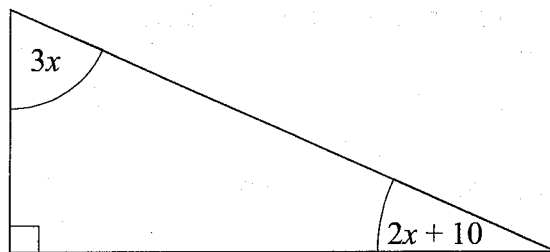

Find the value of size of the smallest angle in the triangle.

$$3x + 2x + 10 + 90 = 180$$

$$5x + 100 = 180$$

$$5x = 80$$

$$x = 16$$

$$3(16) = 48$$

$$2(16) + 10 = 42$$

42

(Total for question 9 is 3 marks)

- 10 Adam has some marbles.  
Bradley has twice as many marbles as Adam.  
Chris has 5 more marbles than Bradley.

In total they have 55 marbles.

How many marbles does Chris have?

$$\text{Adam} = x$$

$$\text{Bradley} = 2x$$

$$\text{Chris} = 2x + 5$$

$$x + 2x + 2x + 5 = 55$$

$$5x + 5 = 55$$

$$5x = 50$$

$$x = 10$$

$$2(10) + 5 = 25$$

25

(Total for question 10 is 3 marks)

- 11 The size of the largest angle in a triangle is three times the size of the smallest angle. The other angle is  $35^\circ$  more than the smallest angle.

Work out, in degrees, the size of each angle in the triangle.  
You must show your working.

$$3x + x + x + 35 = 180$$

$$5x + 35 = 180$$

$$5x = 145$$

$$x = 29$$

$$29 + 35 = 64$$

$$3(29) = 87$$

$$\underline{29^\circ}, \underline{64^\circ}, \underline{87^\circ}$$

(Total for question 11 is 5 marks)

- 12 Lucy is three times as old as Alex.  
Lucy is 7 years older than Megan.  
The sum of their ages is 126.

Find the ratio of Alex's age to Lucy's age to Megan's age.

$$\text{Alex} = x$$

$$\text{Lucy} = 3x$$

$$\text{Megan} = 3x - 7$$

$$x + 3x + 3x - 7 = 126$$

$$7x - 7 = 126$$

$$7x = 133$$

$$x = \underline{\underline{19}}$$

$$3(19) = \underline{\underline{57}}$$

$$57 - 7 = \underline{\underline{50}}$$

$$\underline{\underline{19:57:50}}$$

(Total for question 12 is 4 marks)

Name: \_\_\_\_\_

# GCSE (1 – 9)

## Inequalities

### Instructions

- Use **black** ink or ball-point pen.
- Answer all Questions.
- Answer the Questions in the spaces provided  
– *there may be more space than you need.*
- Diagrams are **NOT** accurately drawn, unless otherwise indicated.
- You must **show all your working out.**

### Information

- The marks for each Question are shown in brackets  
– *use this as a guide as to how much time to spend on each Question.*

### Advice

- Read each Question carefully before you start to answer it.
- Keep an eye on the time.
- Try to answer every Question.
- Check your answers if you have time at the end

- 1  $n$  is an integer such that  $-2 \leq n < 3$   
Write down all the possible values of  $n$ .

$-2, -1, 0, 1, 2$

(Total for question 1 is 2 marks)

- 2 (a) On the number line, show the inequality  $x > -3$

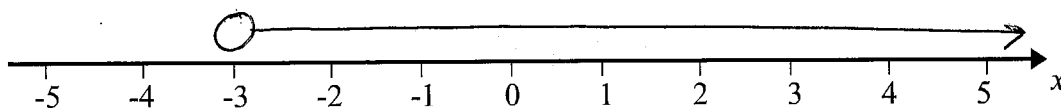

(2)

$1 \leq y < 5$  where  $y$  is an integer.

- (b) Write down all the possible values of  $y$ .

$1, 2, 3, 4$

(2)

- (c) Solve  $4t + 7 \leq 19$

$$-7 \quad -7$$

$$4t \leq 12$$

$$t \leq 3$$

$$t \leq 3$$

(2)

(Total for question 2 is 6 marks)

- 3 Write down the inequality shown on the number line.

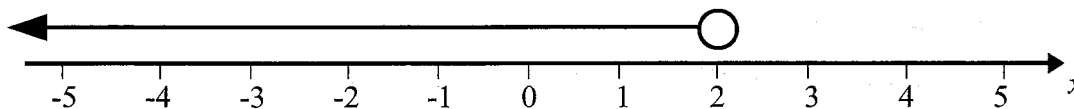

$$x < 2$$

(Total for question 3 is 2 marks)

4 (a)  $-1 < n \leq 3$  where  $n$  is an integer.

(b) Write down all the possible values of  $n$ .

0, 1, 2, 3

(2)

(c) Solve  $2x - 5 > 8$

$$+5 \quad +5$$

$$2x > 13$$

$$x > \frac{13}{2}$$

$$x > \frac{13}{2}$$

(2)

(Total for question 4 is 4 marks)

5 (a) On the number line, show the inequality  $-2 < x < 4$

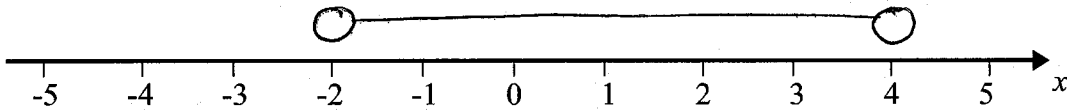

(2)

(b) Write down the inequality shown on the number line.

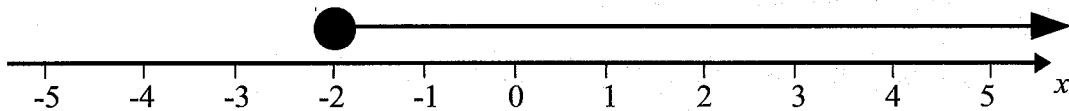

$$x \geq -2$$

(2)

(Total for question 5 is 4 marks)

- 6 (a) On the number line, show the inequality  $n < 2$ .

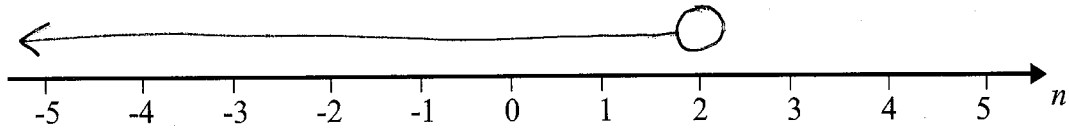

(2)

$4 \leq y < 8$  where  $y$  is an integer.

- (b) Write down all the possible values of  $y$ .

..... 4, 5, 6, 7 .....

(2)

- (c) Solve  $4x + 6 \leq x + 21$

$$\begin{array}{r} -x \\ -x \end{array}$$

$$3x + 6 \leq 21$$

$$\begin{array}{r} -6 \\ -6 \end{array}$$

$$3x \leq 15$$

$$x \leq 5$$

.....  $x \leq 5$  .....

(3)

(Total for question 6 is 7 marks)

- 7 Solve  $4x \leq x + 6$

Show your answer on the number line.

$$4x \leq x + 6$$

$$\begin{array}{r} -x \\ -x \end{array}$$

$$3x \leq 6$$

$$x \leq 2$$

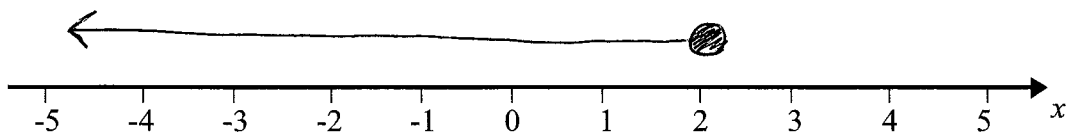

(Total for question 7 is 3 marks)

8 Write down the inequality shown on the number line.

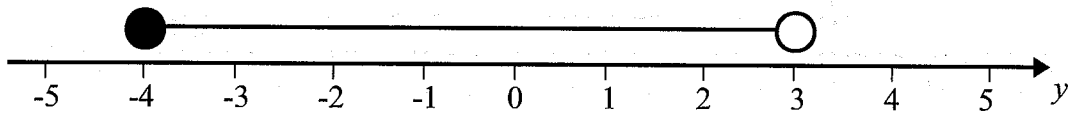

$$-4 \leq y < 3$$

(Total for question 8 is 2 marks)

9 (a) On the number line, show the inequality  $x + 1 \leq 4$

$$x \leq 3$$

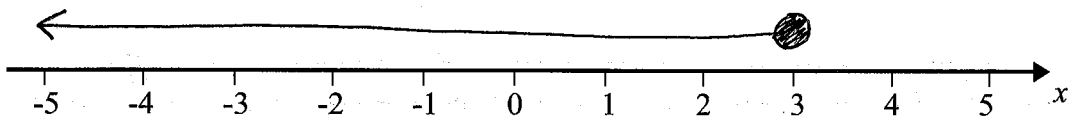

(2)

$5 < 2y < 12$  where  $y$  is an integer.

(b) Write down all the possible values of  $y$ .

$$2.5 < y < 6$$

$$3, 4, 5$$

(2)

(c) Solve  $4 > 19 - 3x$

$$+3x \quad +3x$$

$$3x + 4 > 19$$

$$-4 \quad -4$$

$$3x > 15$$

$$x > 5$$

$$x > 5$$

(2)

(Total for question 9 is 6 marks)

10  $n$  is an integer such that  $-8 < 3n < 10$   
Write down all the possible values of  $n$ .

$$-\frac{8}{3} < n < \frac{10}{3}$$

$$-2.6 < n < 3.3$$

$$-2, -1, 0, 1, 2, 3$$

(Total for question 10 is 2 marks)

11 Write down the inequality shown on the number line.

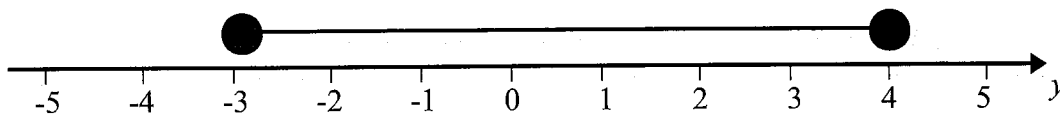

$$-3 \leq y \leq 4$$

(Total for question 11 is 2 marks)

12 (a) On the number line, show the inequality  $-4 < n \leq 5$

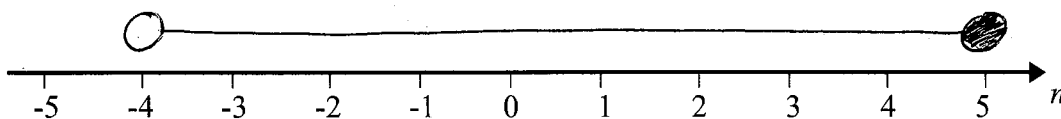

(2)

(b) Write down the inequality shown on the number line.

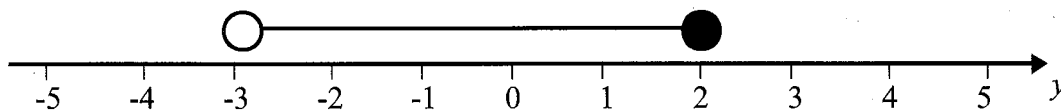

$$-3 < y \leq 2$$

(2)

(Total for question 12 is 4 marks)

13 Solve  $2(3n - 5) > 12$

$$\begin{array}{r} 6n - 10 > 12 \\ +10 \quad +10 \end{array}$$

$$6n > 22$$

$$n > \frac{22}{6}$$

$$n > \frac{11}{3}$$

$$n > \frac{11}{3}$$

(Total for question 13 is 2 marks)

- 14  $n$  is an integer such that  $-3 < 2n < 6$   
Write down all the possible values of  $n$ .

$$\frac{-3}{2} < n < 3$$

$$-1.5 < n < 3$$

.....  
-1, 0, 1, 2

(Total for question 14 is 2 marks)

- 15 Solve  $3(n+1) < 24$

$$3n + 3 < 24$$

$$3n < 21$$

$$n < 7$$

.....  
 $n < 7$

(Total for question 15 is 2 marks)

- 16 Solve  $4(2x+1) > 9$

$$8x + 4 > 9$$

$$8x > 5$$

$$x > \frac{5}{8}$$

.....  
 $x > \frac{5}{8}$

(Total for question 16 is 2 marks)

17 (a) On the number line, show the inequality  $-3 \leq x+2 < 2$

$$-5 \leq x < 0$$

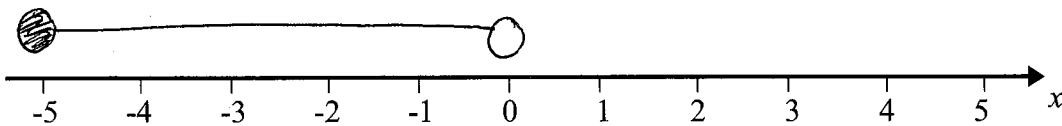

(3)

$1 \leq 2y-3 < 9$  where  $y$  is an integer.

$$\begin{array}{ccc} +3 & +3 & +3 \\ \hline \end{array}$$

(b) Write down all the possible values of  $y$ .

$$4 \leq 2y < 12$$

$$2 \leq y < 6$$

..... 2, 3, 4, 5

(3)

(c) Solve  $4x-4 \leq 7x-19$

$$\begin{array}{ccc} -4x & & -4x \\ \hline \end{array}$$

$$-4 \leq 3x - 19$$

$$\begin{array}{ccc} +19 & & +19 \\ \hline \end{array}$$

$$15 \leq 3x$$

$$5 \leq x$$

$$x \geq 5$$

.....  $x \geq 5$

(3)

(Total for question 17 is 9 marks)

Name: \_\_\_\_\_

## GCSE (1 – 9)

# Real Life Graphs

### Instructions

- Use **black** ink or ball-point pen.
- Answer all questions.
- Answer the questions in the spaces provided – *there may be more space than you need.*
- Diagrams are **NOT** accurately drawn, unless otherwise indicated.
- You must **show all your working out.**

### Information

- The marks for each question are shown in brackets – *use this as a guide as to how much time to spend on each question.*

### Advice

- Read each question carefully before you start to answer it.
- Keep an eye on the time.
- Try to answer every question.
- Check your answers if you have time at the end

- 1 Rebecca went on a bike ride.  
This graph shows Rebecca's distance from home on her bike ride.

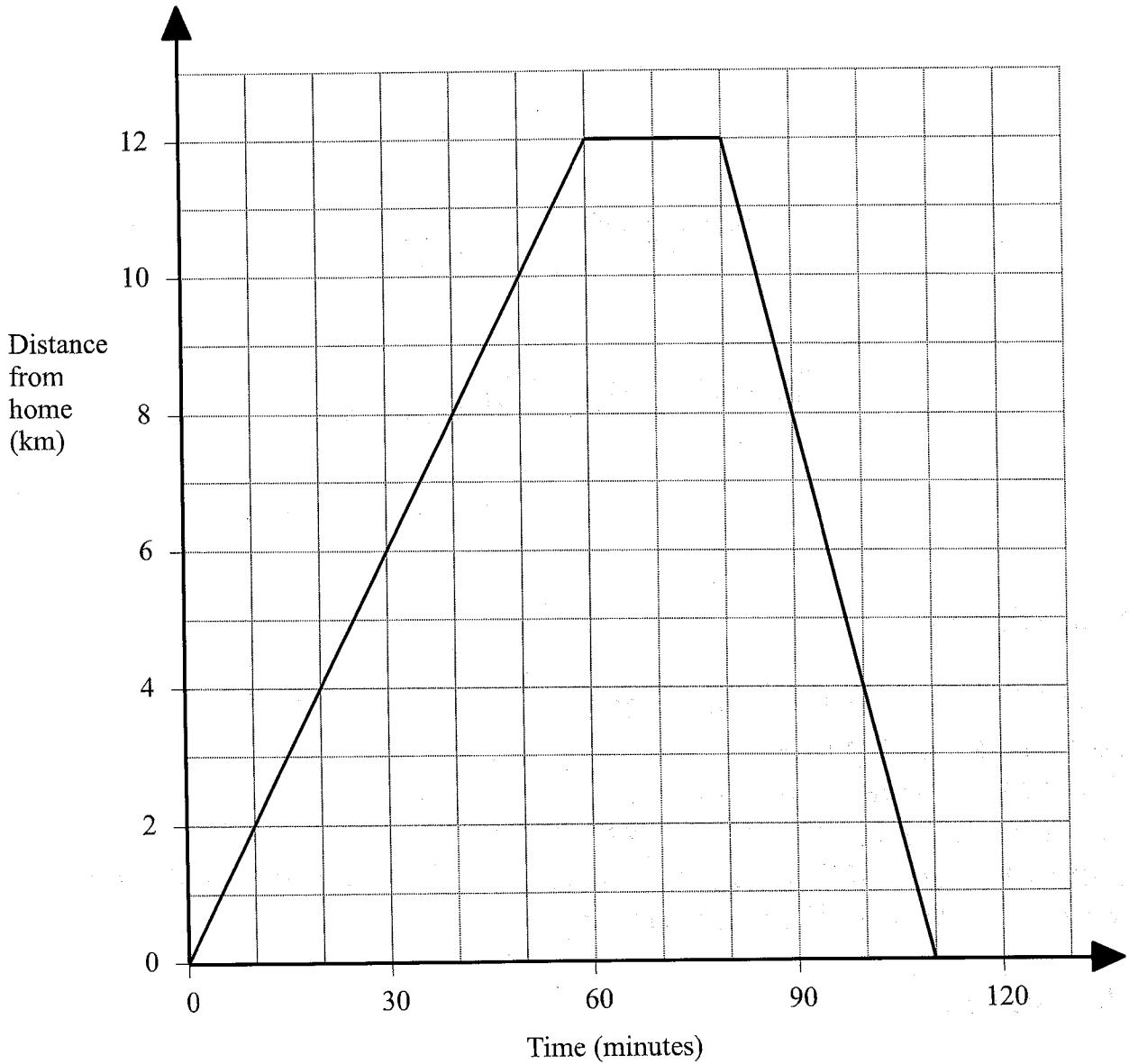

- (a) How far had Rebecca travelled after 30 minutes?

.....6.....km  
(1)

- (b) After 60 minutes, Rebecca stopped for a rest.  
For how many minutes did she rest?

.....20.....minutes  
(1)

- (c) How far did Rebecca travel in total?

.....24.....km  
(1)

(Total for question 1 is 3 marks)

2 Jess drove from Leeds to Liverpool.  
She stopped at a service station for 30 minutes on the way.

Which of these distance time graphs could represent Jess's journey?

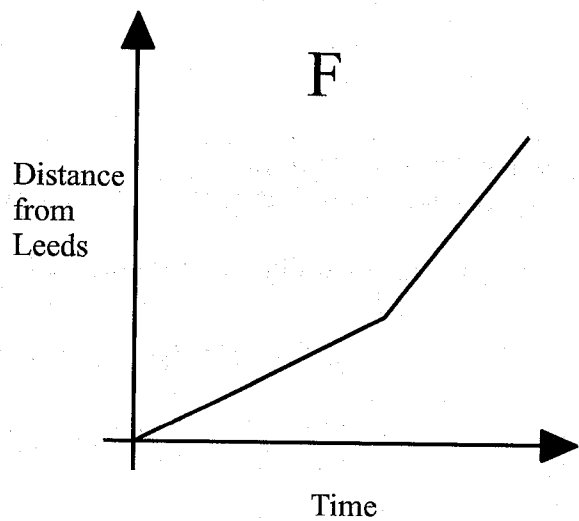
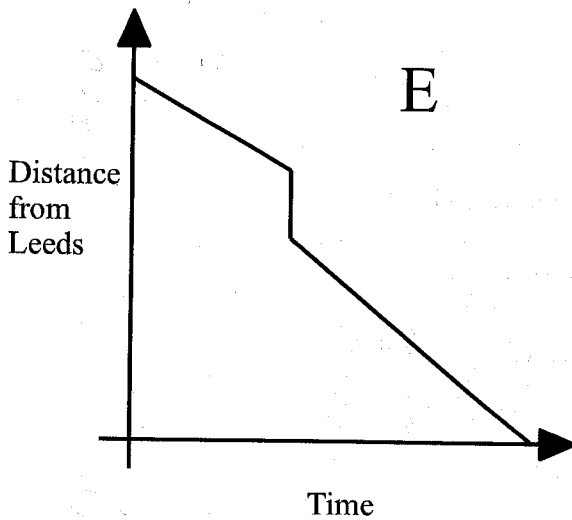
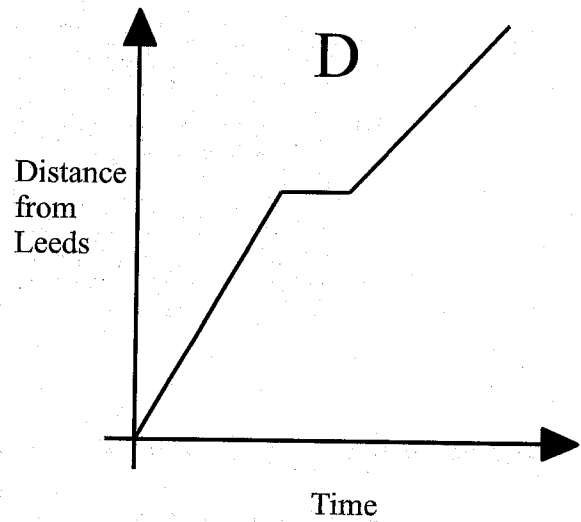
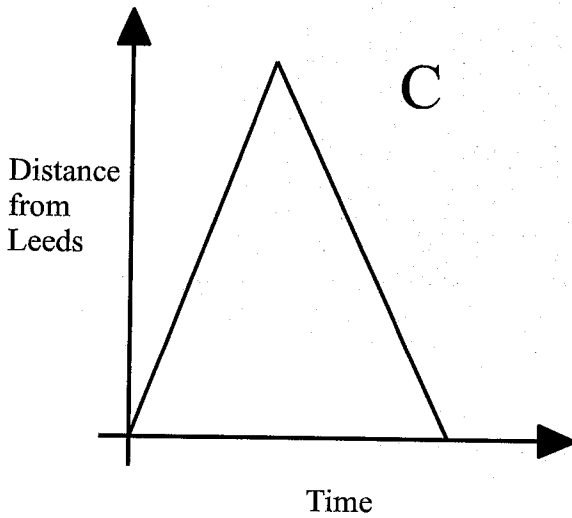
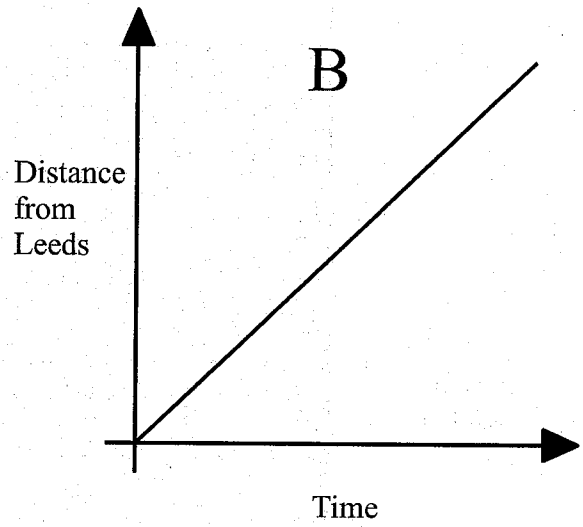
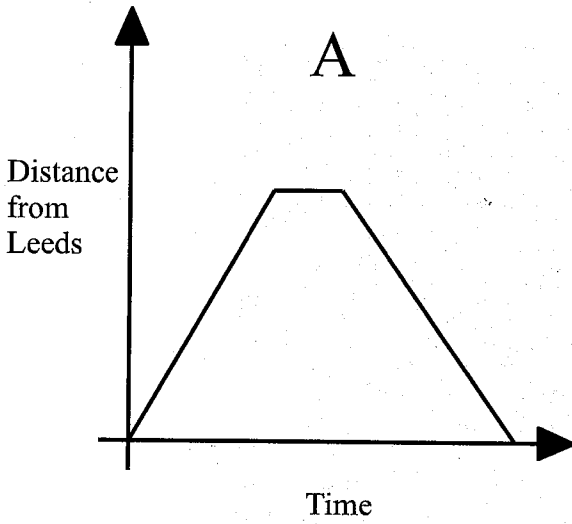

D

(Total for question 2 is 1 mark)

3 Bill is a taxi driver.

You can use this graph to find the cost of a taxi for different distances.

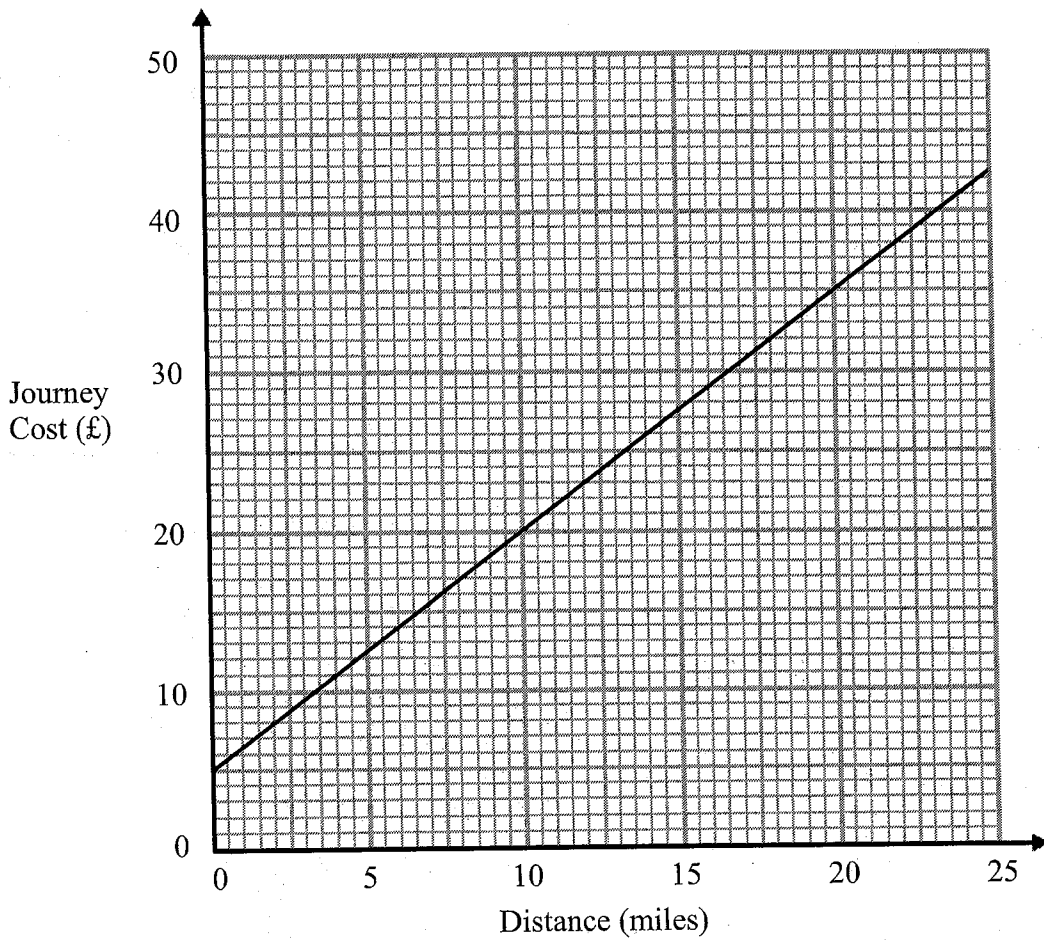

For each journey there is a fixed charge plus a charge for the distance.

(a) How much is the fixed charge?

£.....5.....  
(1)

Bill makes two journeys.

The distance of one journey is 10 miles further than the other journey.

(b) Work out the difference between the two journey costs.

10 mile journey costs £20  
20 mile journey costs £35

£.....15.....  
(2)

(Total for question 3 is 3 marks)

4 John draws a graph to show the amount of petrol his car used on a 250 mile journey.

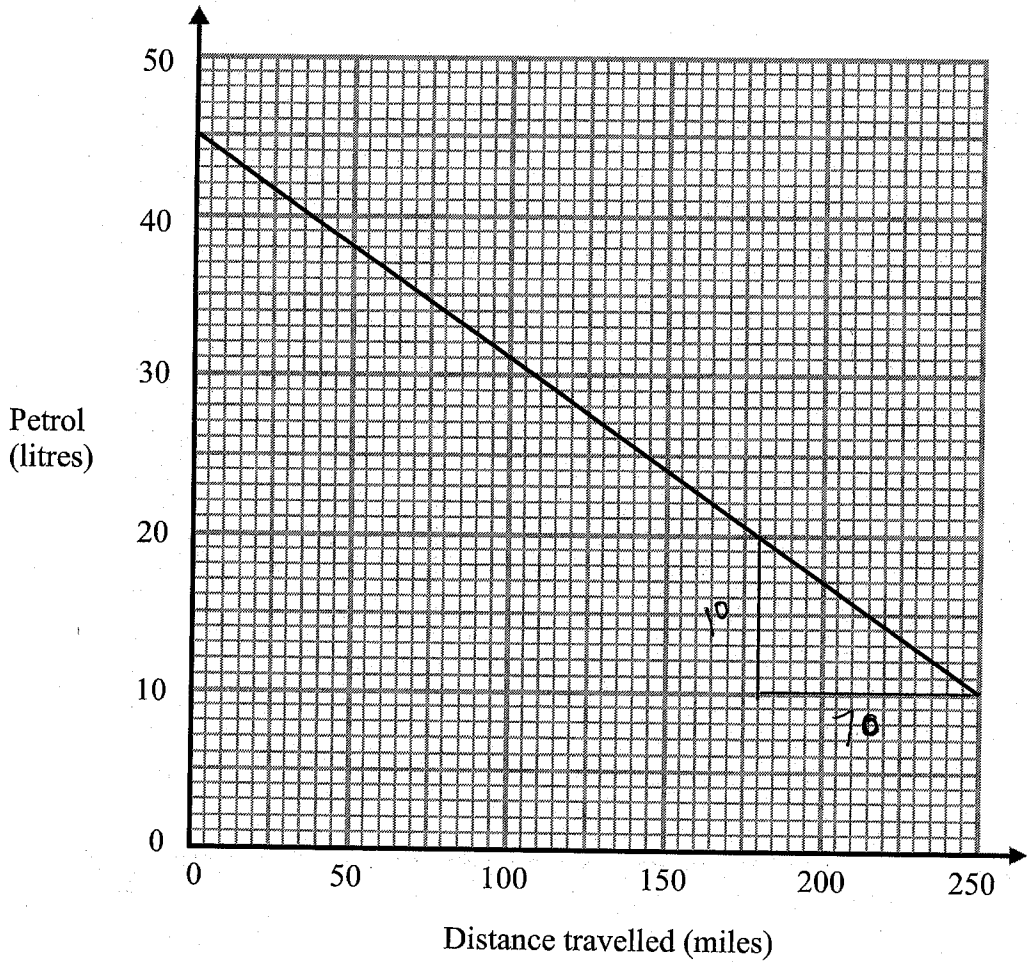

(a) How much petrol was in John's car at the start of his journey?

.....45.....litres  
(1)

(b) How many more miles can John's car travel before it runs out of petrol?

.....70.....miles  
[70 - 72] (1)

(c) What assumption have you made to calculate your answer to (b)?

.....petrol is used at the same rate.....

(1)

(Total for question 4 is 3 marks)

5

Bernie is filling up a swimming pool.

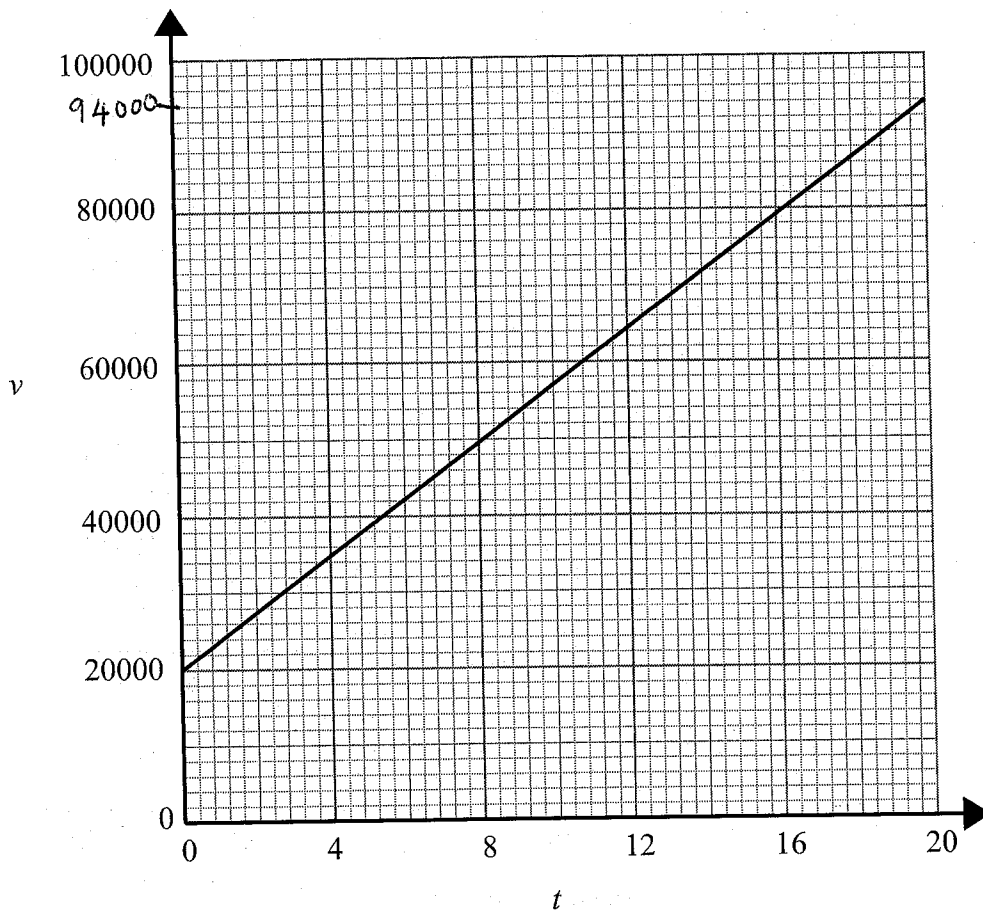
The graph shows the volume  $v$  of water in the swimming pool at time  $t$  hours.

Work out the rate of that the water is flowing into the pool.

Give your answer in litres per hour.

$$\frac{74000}{20} = 3700$$

$$\begin{array}{r} \dots\dots\dots 3700 \dots\dots\dots \text{ l/hr} \\ 3700 - 3750^{(2)} \end{array}$$

(Total for question 5 is 2 marks)

6 Emily drove to the beach. She stayed at the beach and then she drove back home.

Here is Emily's travel graph.

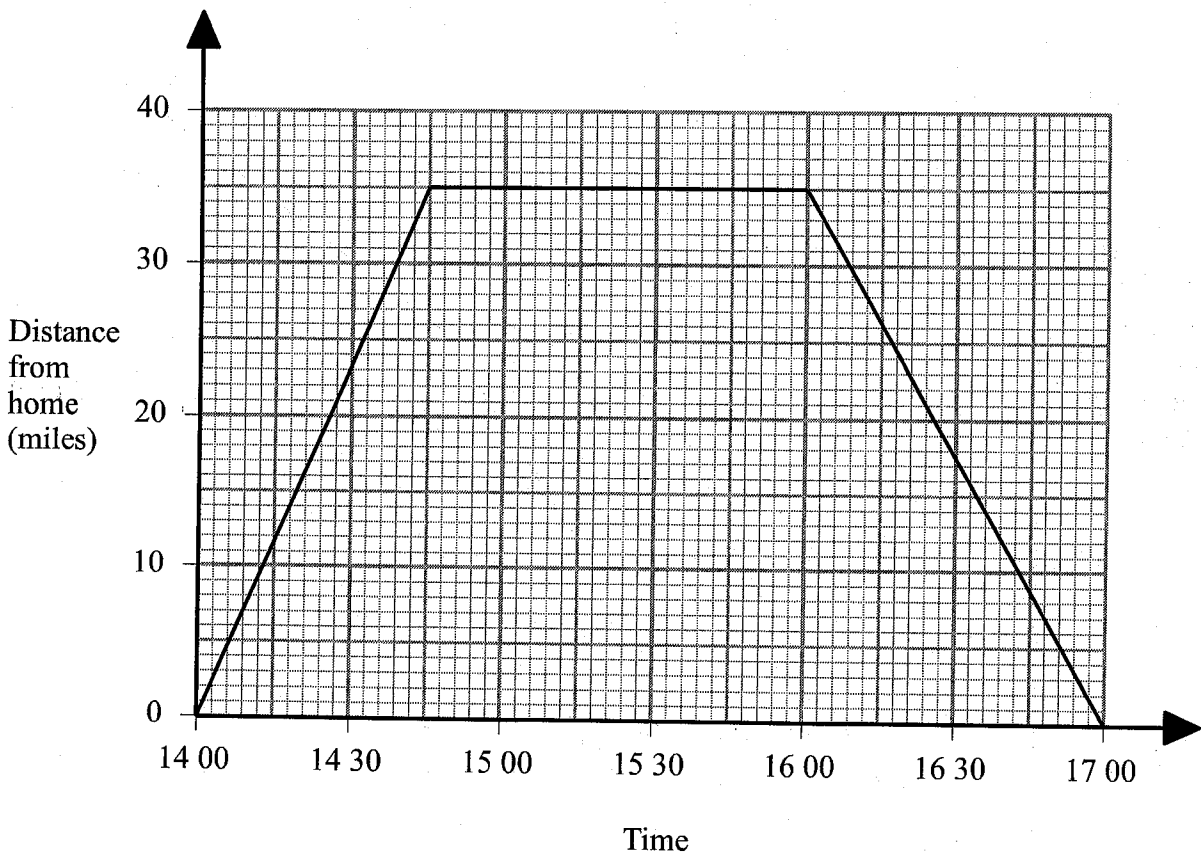

(a) For how many minutes did Emily stay at the beach?

1445 to 1600

.....75.....minutes  
(1)

(b) What was Emily's average speed on her **journey to the beach**?

35 miles in 45 mins  
0.75 hours

$$\frac{35}{0.75} = 46.6 \text{ m/h}$$

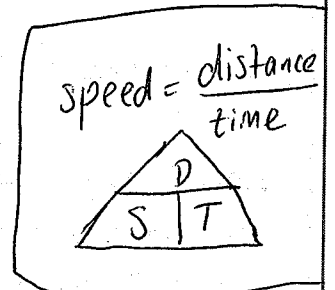

.....47.....miles/hour  
(2)

(Total for question 6 is 3 marks)

$$\left[ \frac{140}{3} \text{ miles/hour} \right]$$

7

Dawn drove from London to Birmingham. She made one stop at a service station.

Here is part of Dawn's travel graph.

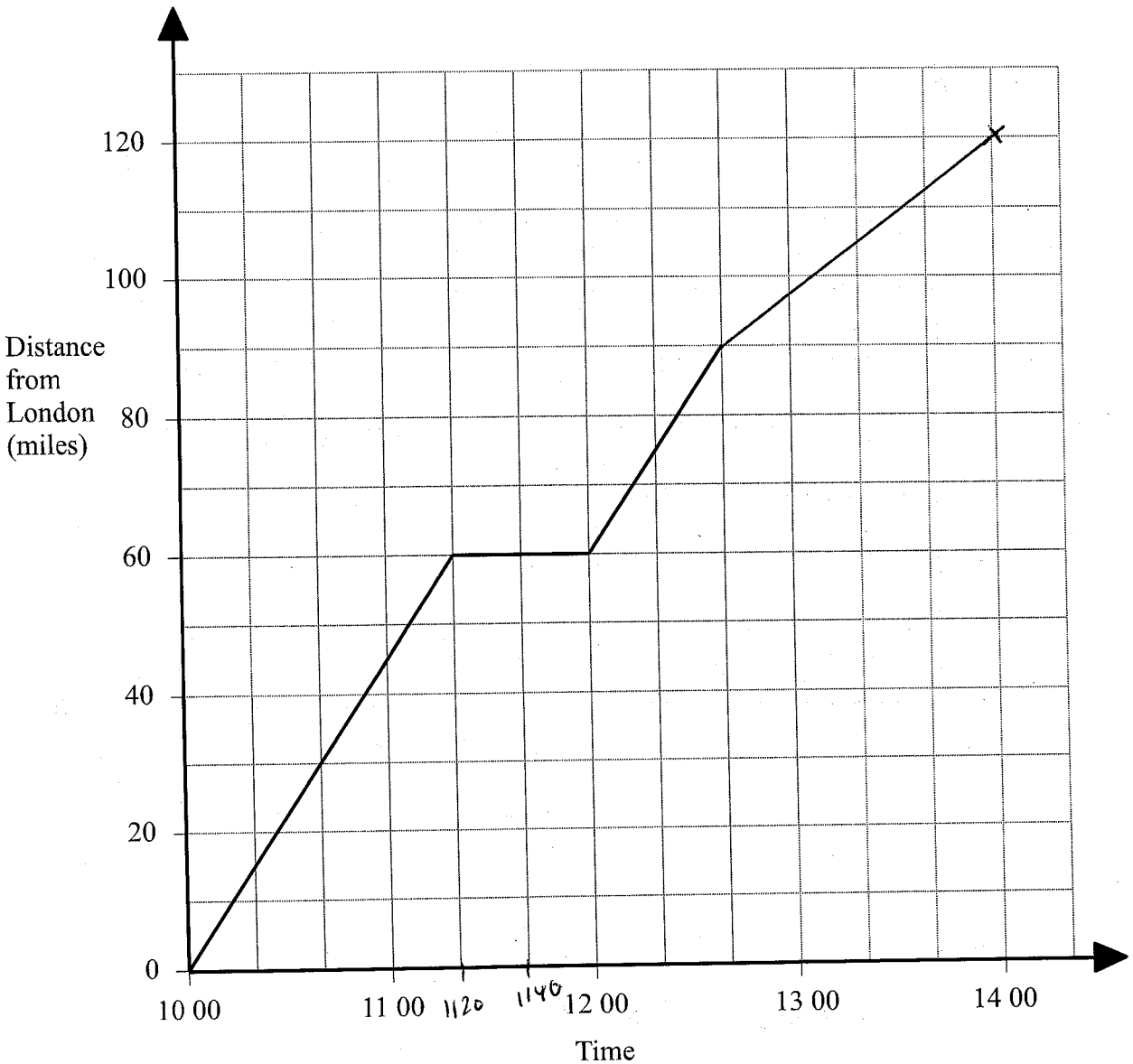

(a) For how many minutes did Dawn stop at the service station?

..... 40 ..... minutes  
(1)

(b) What was Dawn's average speed between London and the service station?

30 miles in 40 mins  
15 miles in 20 mins  
60 miles in 80 mins  
~~60~~ ÷  $\frac{4}{3}$  = 45  
45 miles in 60 mins  
..... 45 ..... miles/hour  
(2)

(c) Birmingham is 120 miles from London.  
Dawn arrived in Birmingham at 14 00.

Complete the graph.

(2)

(Total for question 7 is 5 marks)

Name: \_\_\_\_\_

## GCSE (1 – 9)

### HCF and LCM

#### Instructions

- Use **black** ink or ball-point pen.
- Answer all Questions.
- Answer the Questions in the spaces provided  
– *there may be more space than you need.*
- Diagrams are **NOT** accurately drawn, unless otherwise indicated.
- You must **show all your working out.**

#### Information

- The marks for each Question are shown in brackets  
– *use this as a guide as to how much time to spend on each Question.*

#### Advice

- Read each Question carefully before you start to answer it.
- Keep an eye on the time.
- Try to answer every Question.
- Check your answers if you have time at the end

1 Write 40 as a product of its prime factors.

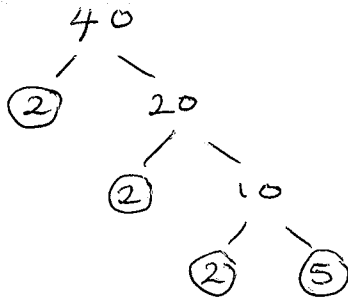

$$2 \times 2 \times 2 \times 5$$

or  $2^3 \times 5$

$$2^3 \times 5$$

(Total for question 1 is 2 marks)

2 Write 72 as a product of its prime factors.

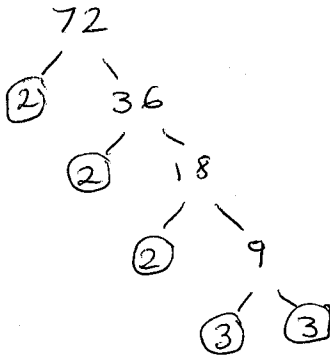

$$2 \times 2 \times 2 \times 3 \times 3$$

or  $2^3 \times 3^2$

$$2^3 \times 3^2$$

(Total for question 2 is 2 marks)

3 Write 98 as a product of its prime factors.

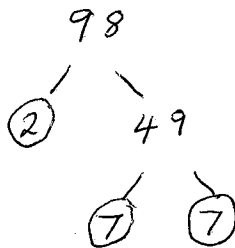

$$2 \times 7 \times 7$$

or  $2 \times 7^2$

$$2 \times 7^2$$

(Total for question 3 is 2 marks)

4 Write 240 as a product of its prime factors.

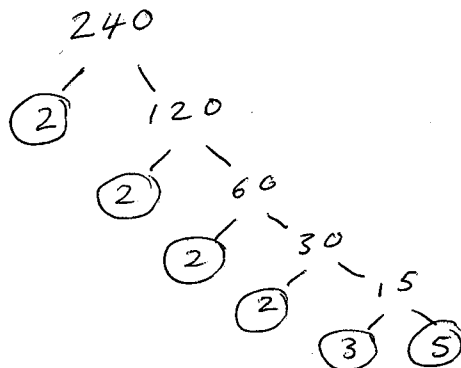

$$2 \times 2 \times 2 \times 2 \times 3 \times 5$$

or  $2^4 \times 3 \times 5$

$$2^4 \times 3 \times 5$$

(Total for question 4 is 2 marks)

5 Find the highest common factor (HCF) of 60 and 114

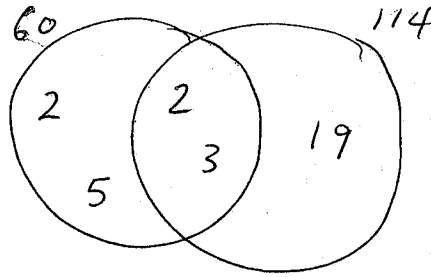
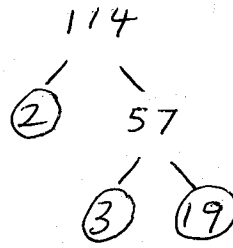
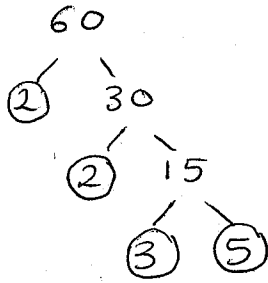

$$HCF = 2 \times 3 = 6$$

6

(Total for question 5 is 3 marks)

6 Find the lowest common multiple (LCM) of 120 and 150

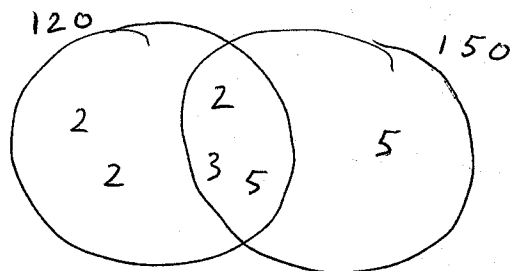
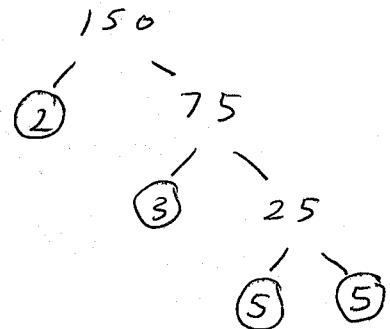
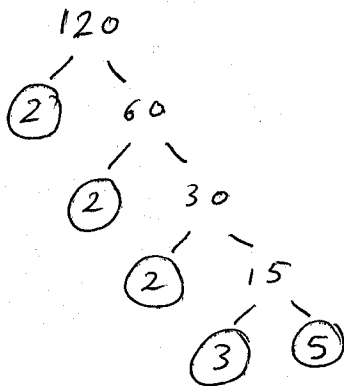

$$\begin{aligned} LCM &= 120 \times 5 \\ &= 600 \end{aligned}$$

600

(Total for question 6 is 3 marks)

7 Find the highest common factor (HCF) of 84 and 120

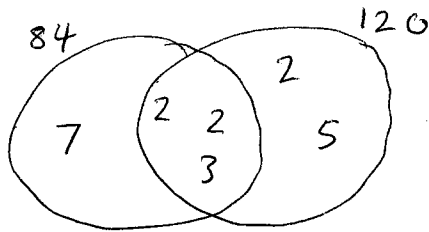
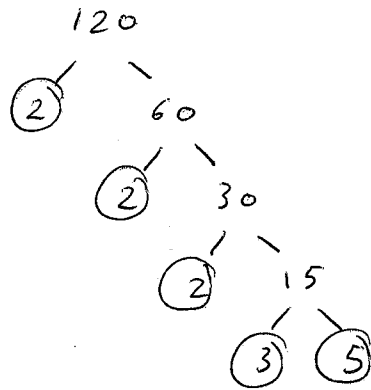
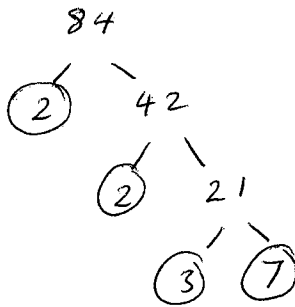

$$\begin{aligned} \text{HCF} &= 2 \times 2 \times 3 \\ &= 12 \end{aligned}$$

12

(Total for question 7 is 3 marks)

8 Find the lowest common multiple (LCM) of 70 and 56

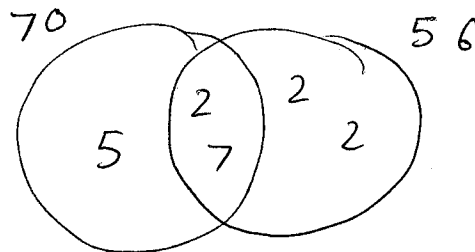
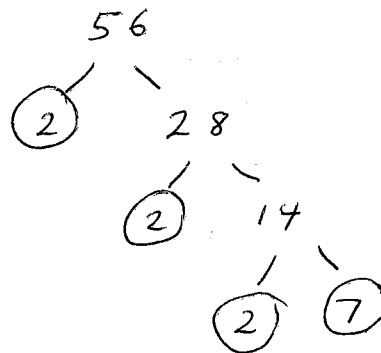
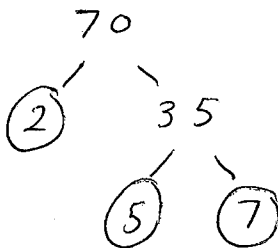

$$\begin{aligned} \text{LCM} &= 70 \times 2 \times 2 \\ &= 280 \end{aligned}$$

280

(Total for question 8 is 3 marks)

9 Two buses, bus A and bus B, both use the same bus stop.

Bus A runs every 10 minutes.

$$10 = 2 \times 5$$

Bus B runs every 14 minutes.

$$14 = 2 \times 7$$

Both buses are at the bus stop at 11 am.

What time will both buses next both be at the bus stop.

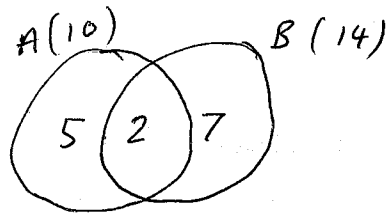

$$\begin{aligned} \text{LCM} &= 14 \times 5 \\ &= 70 \end{aligned}$$

70 minutes after 11 am

.....  
12:10 pm

(Total for question 9 is 3 marks)

10 Light A flashes every 8 seconds.

$$8 = 2 \times 2 \times 2$$

Light B flashes every 20 seconds.

$$20 = 2 \times 2 \times 5$$

Both lights flash at the same time.

Work out how long it will take for both lights to flash at the same time again.

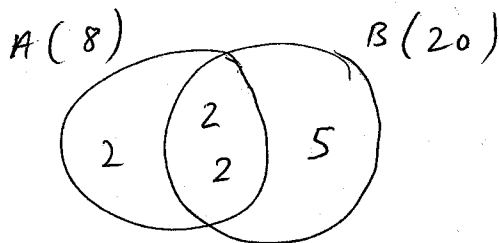

$$\text{LCM} = 20 \times 2 = 40$$

.....  
40

..... seconds

(Total for question 10 is 3 marks)

11

$648 = 2^3 \times 3^4$

$540 = 2^2 \times 3^3 \times 5$

(a) Write down the highest common factor (HCF) of 648 and 540.

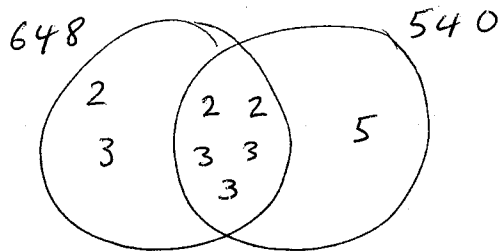

$$2 \times 2 \times 3 \times 3 \times 3$$

$$4 \times 27$$

$$\underline{\quad 108 \quad}$$

(1)

(b) Find the lowest common multiple (LCM) of 648 and 540.

$648 \times 5$

$$\left[ \frac{6480}{2} = 3240 \right]$$

$$\underline{\quad 3240 \quad}$$

(2)

**(Total for question 11 is 3 marks)**

12

$A = 2^2 \times 3 \times 5^2$

$B = 2^3 \times 3^2 \times 7$

(a) Write down the highest common factor (HCF) of A and B.

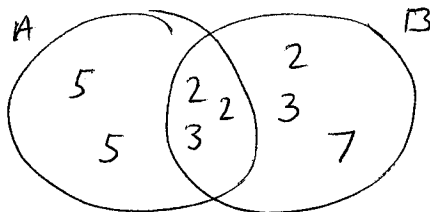

$$2 \times 2 \times 3$$

$$\underline{\quad 12 \quad}$$

(1)

(b) Find the lowest common multiple (LCM) of A and B.

$$2 \times 2 \times 2 \times 3 \times 3 \times 5 \times 5 \times 7$$

$$8 \times 9 \times 25 \times 7$$

$$72 \times 175$$

$$\begin{array}{r} 175 \\ \times 72 \\ \hline 350 \\ 12250 \\ \hline 12600 \end{array}$$

$$\underline{\quad 12600 \quad}$$

(2)

**(Total for question 12 is 3 marks)**

- 13 Find the lowest common multiple (LCM) of 12, 15 and 18.

$$\cancel{12 \times 2}$$

$$12 = 2 \times 2 \times 3$$

$$15 = 3 \times 5$$

$$18 = 2 \times 3 \times 3$$

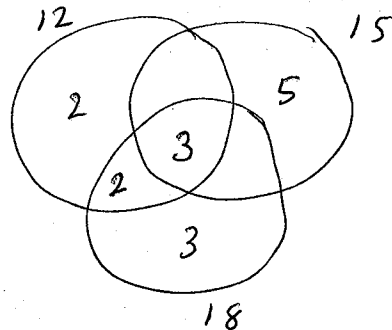

$$\begin{aligned} \text{LCM} &= 18 \times 2 \times 5 \\ &= 18 \times 10 \\ &= 180 \end{aligned}$$

180

(Total for question 13 is 3 marks)

- 14 Light A flashes every 5 seconds. 5  
Light B flashes every 6 seconds.  $2 \times 3$   
Light C flashes every 7 seconds. 7

All three lights flash at the same time.

Work out how long it will take for all three lights to flash at the same time again.

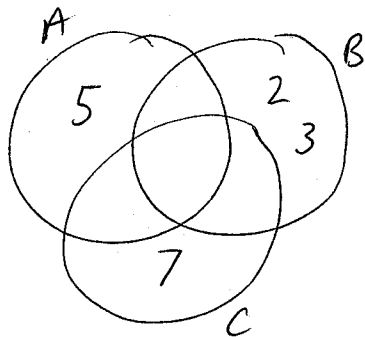

$$\begin{aligned} 7 \times 5 \times 6 \\ 35 \times 6 = 210 \end{aligned}$$

210

..... seconds

(Total for question 14 is 3 marks)

15 Find the highest common factor (HCF) of 72, 90 and 126

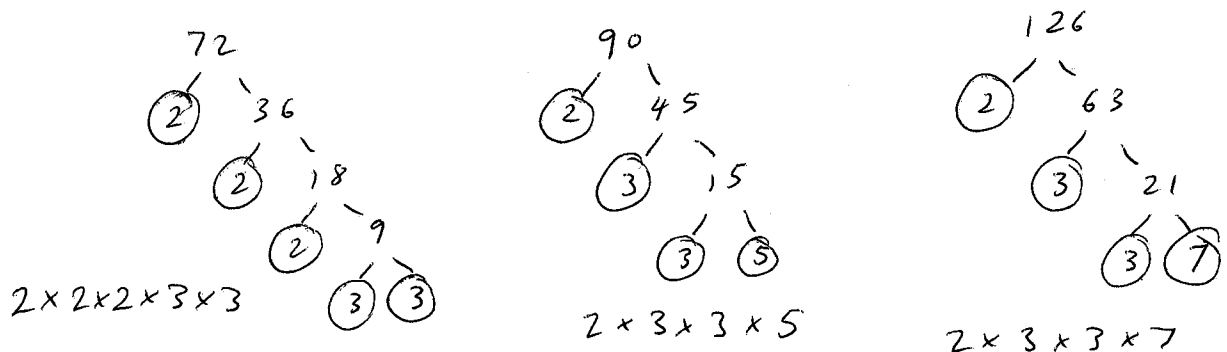

$2 \times 2 \times 2 \times 3 \times 3$

$2 \times 3 \times 3 \times 5$

$2 \times 3 \times 3 \times 7$

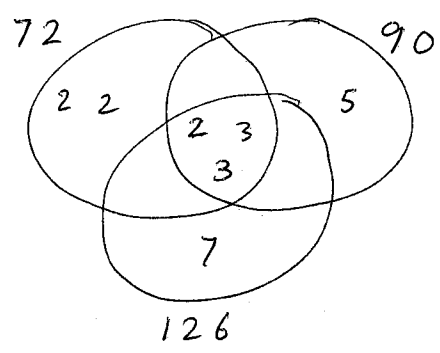

$HCF = 2 \times 3 \times 3$   
 $= 2 \times 9$   
 $= 18$

18

(Total for question 15 is 3 marks)

16 Kenny is thinking of two numbers **greater than 10**.  
 He says: "The highest common factor (HCF) of my two numbers is 7  
 The lowest common multiple (LCM) of my two numbers is 84"

Write down the two numbers that Kenny is thinking of.

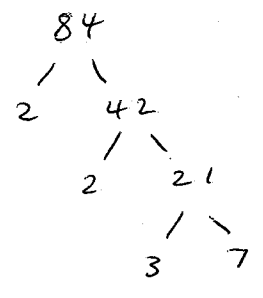
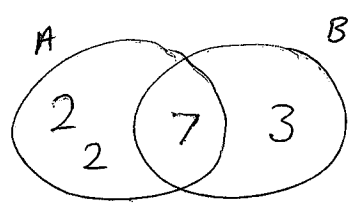

$A = 2 \times 2 \times 7$   
 $= 28$

$B = 3 \times 7$   
 $= 21$

21 and 28

(Total for question 16 is 3 marks)

Name: \_\_\_\_\_

# GCSE (1 – 9)

## Indices

### Instructions

- Use **black** ink or ball-point pen.
- Answer all Questions.
- Answer the Questions in the spaces provided  
– *there may be more space than you need.*
- Diagrams are **NOT** accurately drawn, unless otherwise indicated.
- You must **show all your working out.**

### Information

- The marks for each Question are shown in brackets  
– *use this as a guide as to how much time to spend on each Question.*

### Advice

- Read each Question carefully before you start to answer it.
- Keep an eye on the time.
- Try to answer every Question.
- Check your answers if you have time at the end

1 (a) Simplify  $x^8 \times x^3$

$$x^{11}$$

(1)

(b) Simplify  $(5y)^3$

$$5y \times 5y \times 5y$$

$$125y^3$$

(1)

(c) Simplify  $\frac{w^7}{w^4}$

$$w^3$$

(1)

(Total for question 1 is 3 marks)

2 (a) Simplify  $a^9 \times a^4$

$$a^{13}$$

(1)

(b) Simplify  $(4b^2c)^3$

$$4b^2c \times 4b^2c \times 4b^2c$$

$$64b^6c^3$$

(2)

(c) Simplify  $d^9 \div d^4$

$$d^5$$

(1)

(Total for question 2 is 4 marks)

3 (a) Simplify  $2m^2 \times 5n^6$

$$10m^2n^6$$

(1)

(b) Simplify  $15p^3 \div 3p^4$

$$5p^{-1}$$

(2)

(Total for question 3 is 3 marks)

4 (a) Simplify  $(t^3)^4$

$$t^{12}$$

(b) Simplify  $12m^2n^6 \div 3mn^4$

$$4mn^2$$

(1)

(2)

(Total for question 4 is 3 marks)

5 Simplify  $5m^2n^3 \times 3mn^4$

$$15m^3n^7$$

(Total for question 5 is 2 marks)

6 (a) Write down the value of  $5^{-3}$

$$\frac{1}{125}$$

(b) Write down the value of  $5^0$

(1)

$$1$$

(1)

(Total for question 6 is 2 marks)

7 Work out the value of  $5^2 \times 2^3$

$$25 \times 8$$

$$200$$

(Total for question 7 is 1 mark)

8 Write down the value of  $2^{-3}$

$$\frac{1}{8}$$

(Total for question 8 is 1 mark)

9  $y^2 \times y^a = y^7$

(a) Find the value of  $a$ .

$(y^4)^b = y^{12}$

(b) Find the value of  $b$ .

5

(1)

3

(1)

(Total for question 9 is 2 marks)

10 (a) Given  $\frac{x^6}{x^a} = x^8$

Find the value of  $a$ .

$a = -2$

(1)

(b) Simplify  $(2m^2)^4$

$16m^8$

(2)

(Total for question 10 is 3 marks)

- 11 (a) Write  $\frac{3^4 \times 3^5}{3^2}$  as a power of 3

$$\frac{3^9}{3^2} = 3^7$$

$$\frac{3^7}{\dots\dots\dots}$$

(2)

- (b) Write down the value of  $3^{-3}$

$$\frac{1}{27}$$

(1)

- (c) Write down the value of  $3^0$

$$1$$

(1)

(Total for question 11 is 4 marks)

- 12 Work out the value of  $\frac{2^9 \times 2^{-2}}{2^4}$

$$\frac{2^7}{2^4} = 2^3 = 8$$

$$\frac{2^3}{\dots\dots\dots} 8$$

(Total for question 12 is 2 marks)

- 13 Work out the value of  $(2^2)^3$

$$4^3 = 64$$

$$\frac{64}{\dots\dots\dots}$$

(Total for question 13 is 1 mark)

14 (a) Simplify  $p^3 \times p^5$

$$\frac{p^8}{(1)}$$

(b) Simplify  $(4ab^2)^3$

$$\frac{64a^3b^6}{(2)}$$

(c) Simplify  $\frac{16m^7n^3}{4m^3n}$

$$\frac{4m^4n^2}{(2)}$$

(Total for question 14 is 5 marks)

15  $1000^4 = 10^x$

Find the value of  $x$ .

$$(10^3)^4 = 10^x$$
$$10^{12} = 10^x$$

$$\frac{12}{(2)}$$

(Total for question 15 is 1 mark)

16 Work out the value of  $\frac{2^3 \times 2}{2^5}$

$$\frac{2^4}{2^5} = 2^{-1} = \frac{1}{2}$$

$$\frac{1}{2}$$

(Total for question 16 is 2 marks)

17 Write down the reciprocal of 8

$$\frac{1}{8}$$

(Total for question 17 is 1 mark)

18 (a) Simplify  $9p^3 \times 2p^{-2}$

$$\frac{18p}{\dots\dots\dots} \quad (1)$$

(b) Simplify  $(5x^3y^2)^3$

$$\frac{125x^9y^6}{\dots\dots\dots} \quad (2)$$

(c)  $p^3 \times p^5 = p^{12} \times p^y$

Find the value of  $y$

$$p^8 = p^{12} \times p^y$$

$$\frac{-4}{\dots\dots\dots} \quad (2)$$

(Total for question 18 is 5 marks)

19  $10^x = 1$

Write down the value of  $x$ .

$$\frac{0}{\dots\dots\dots}$$

(Total for question 19 is 1 mark)

20 Write  $5^4 \times 5$  as a power of 5

$$\frac{5^5}{\dots\dots\dots}$$

(Total for question 20 is 1 mark)

21 Write down the reciprocal of 2

$$\frac{1}{2} \dots\dots\dots$$

(Total for question 21 is 1 mark)

22 (a) Simplify  $5c^2d^3 \times 2d$

$$\frac{10c^2d^4}{(1)}$$

(b) Write  $64 \times 4^5$  as a power of 4

$$4^3 \times 4^5 = 4^8$$

$$\frac{4^8}{(2)}$$

(c) Simplify  $p^3 \times (p^5)^2$

$$p^3 \times p^{10}$$

$$\frac{p^{13}}{(2)}$$

(Total for question 22 is 5 marks)

23  $p^9 \times p^5 = p^x$

Write down the value of  $x$

$$\frac{14}{(1)}$$

(Total for question 23 is 1 mark)

24 Write down the reciprocal of  $\frac{1}{3}$

$$\frac{3}{(1)}$$

(Total for question 24 is 1 mark)

25 Simplify  $\frac{10p^3q^5r}{4p^3q^6}$

$$\frac{\overset{5}{\cancel{10}} \overset{3}{\cancel{p}} \overset{5}{\cancel{q}} r}{\underset{2}{\cancel{4}} \overset{3}{\cancel{p}} \overset{6}{\cancel{q}}}$$

$$\frac{5r}{2q}$$

$$\frac{5r}{2q}$$

(Total for question 25 is 2 marks)

OR  $2.5rq^{-1}$